

SEC.NO.	A	B	T	WT.Kg/mtr.
5300	75.00	42.00	4.10	1.682

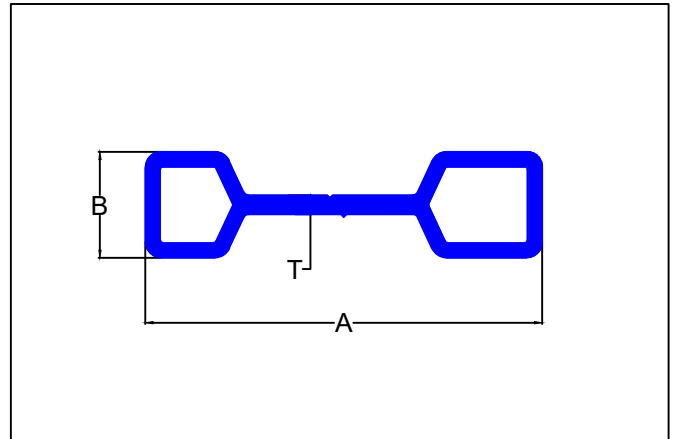

SEC.NO.	A	B	T	WT.Kg/mtr.
5301	75.00	20.00	3.60	1.287

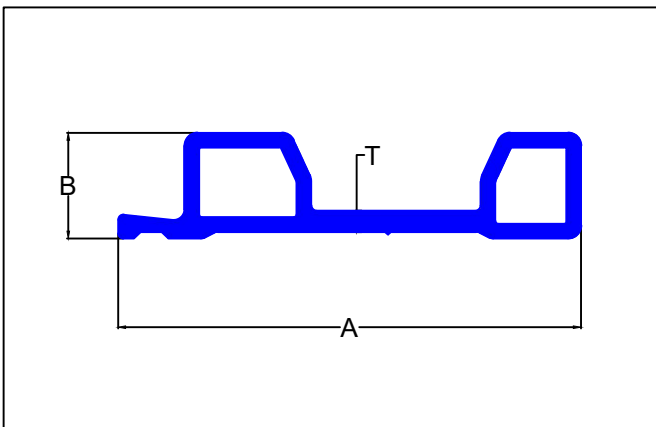

SEC.NO.	A	B	T	WT.Kg/mtr.
5302	87.50	20.00	4.00	1.491

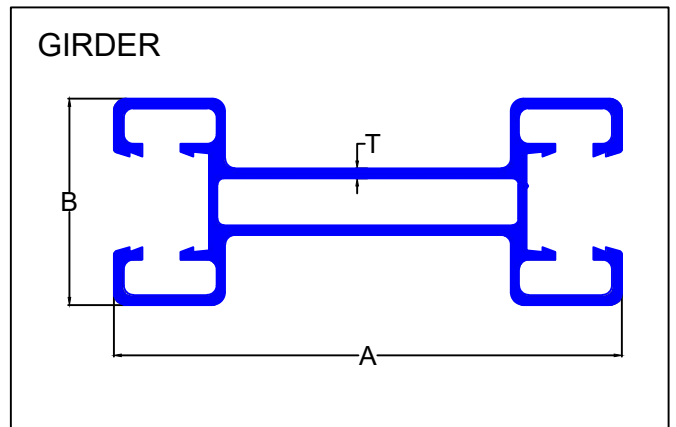

SEC.NO.	A	B	T	WT.Kg/mtr.
5303	160.00	65.00	3.10	4.801

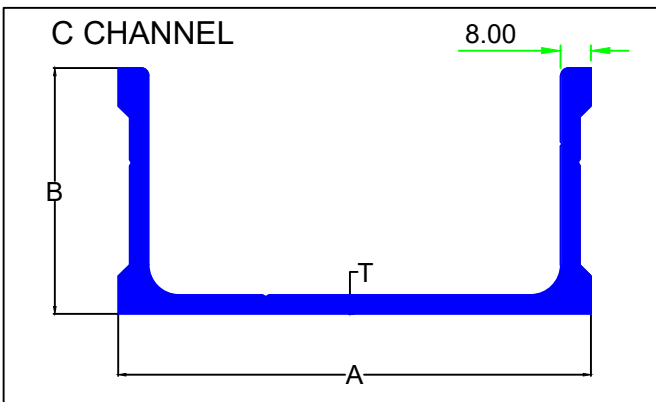

SEC.NO.	A	B	T	WT.Kg/mtr.
5304	125.00	65.00	5.00	3.664

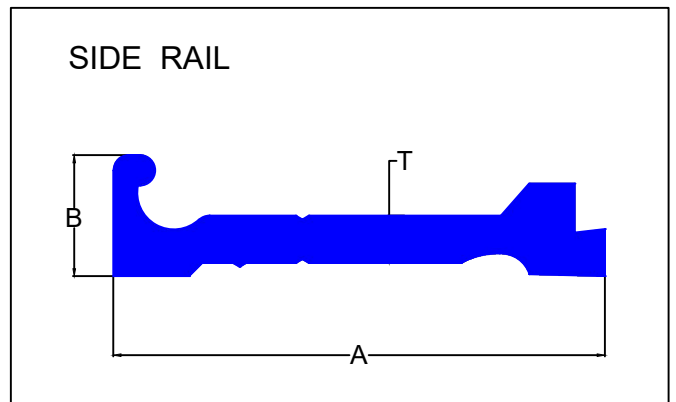

SEC.NO.	A	B	T	WT.Kg/mtr.
5305	65.00	16.00	6.25	1.302

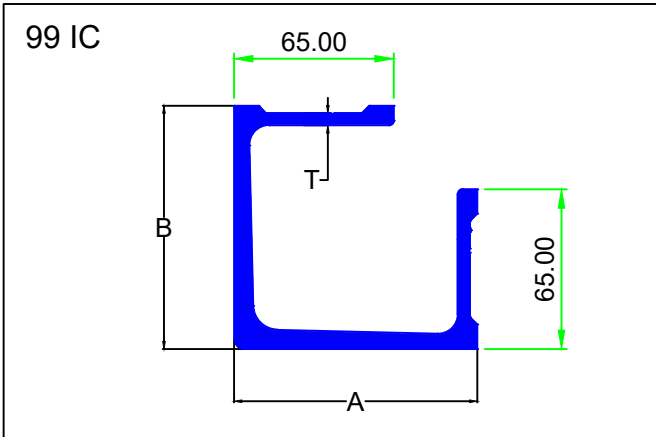

SEC.NO.	A	B	T	WT.Kg/mtr.
5306	99.00	99.00	5.00	5.553

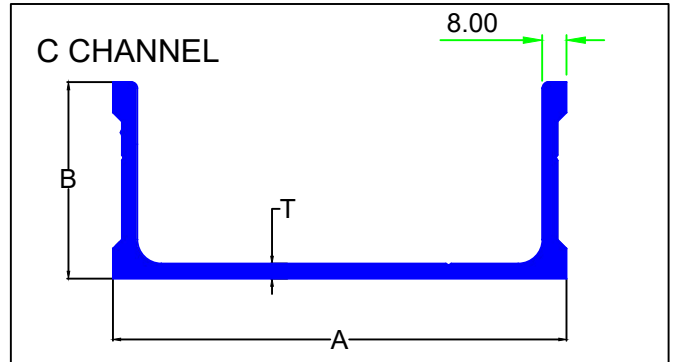

SEC.NO.	A	B	T	WT.Kg/mtr.
5307	150.00	65.00	5.00	4.004
5324	175.00	65.00	4.00	3.913
5339	200.00	65.00	4.00	4.183

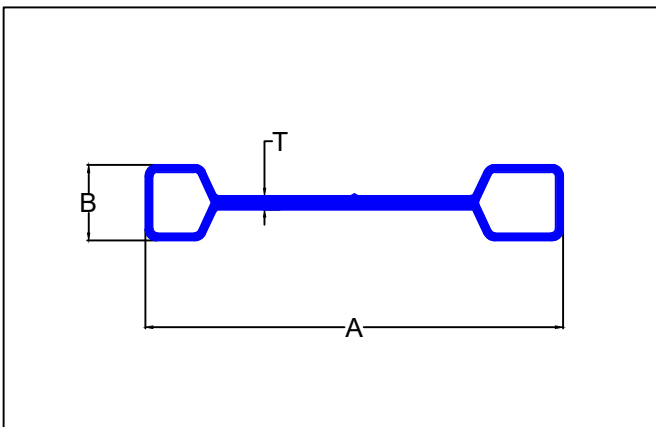

SEC.NO.	A	B	T	WT.Kg/mtr.
5308	110.50	20.00	3.60	1.348

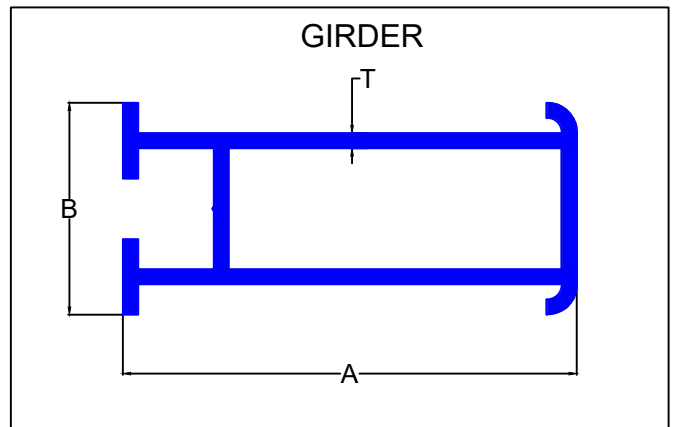

SEC.NO.	A	B	T	WT.Kg/mtr.
5309	150.00	70.00	5.00	5.992

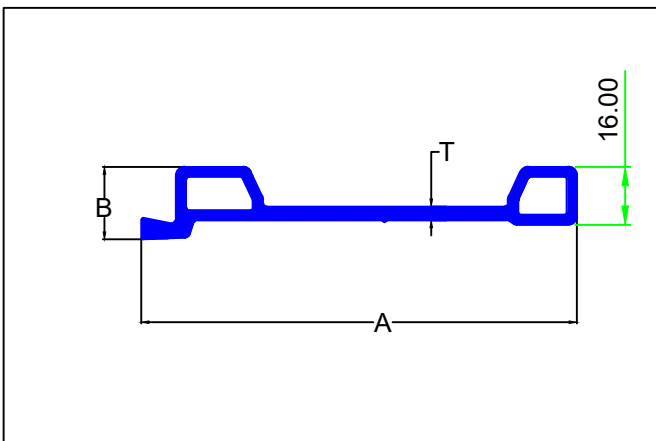

SEC.NO.	A	B	T	WT.Kg/mtr.
5310	120.00	20.00	3.80	1.768

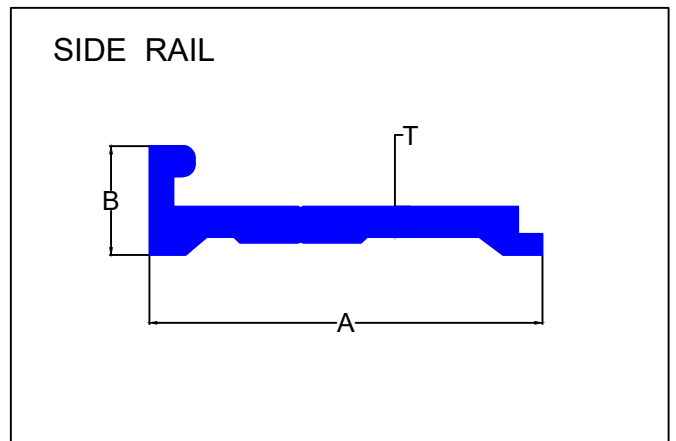

SEC.NO.	A	B	T	WT.Kg/mtr.
5311	65.00	18.00	5.00	1.167

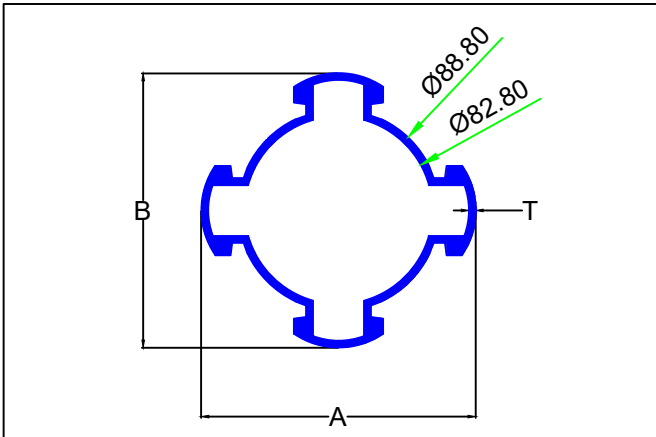

SEC.NO.	A	B	T	WT.Kg/mtr.
5312	121.00	121.00	3.00	4.200

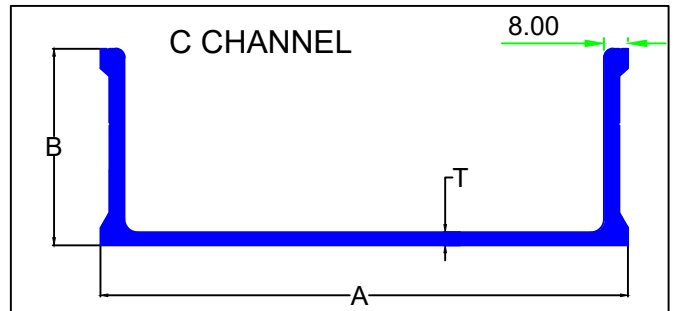

SEC.NO.	A	B	T	WT.Kg/mtr.
5315	174.50	65.00	4.30	3.863
5316	199.50	65.00	5.60	4.778
5317	225.00	65.00	4.00	4.453
5323	159.50	65.00	4.50	3.654

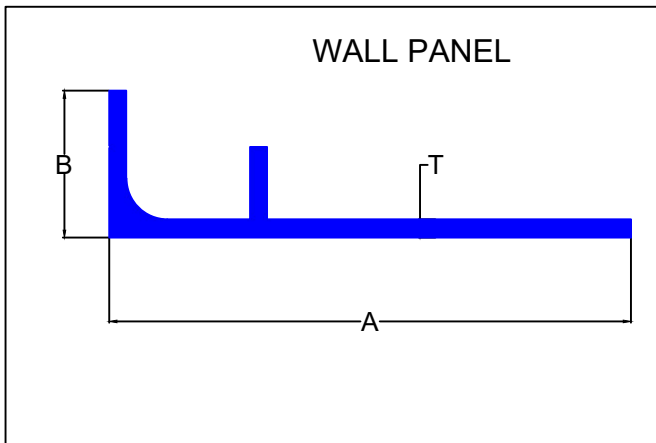

SEC.NO.	A	B	T	WT.Kg/mtr.
5318	230.00	64.75	8.00	6.952

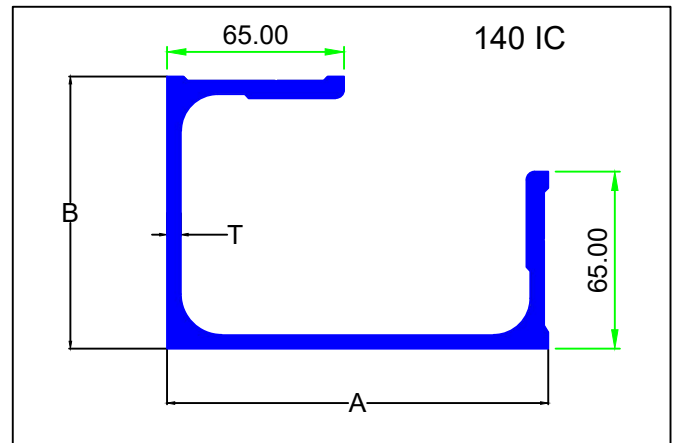

SEC.NO.	A	B	T	WT.Kg/mtr.
5319	140.00	100.00	5.00	5.483

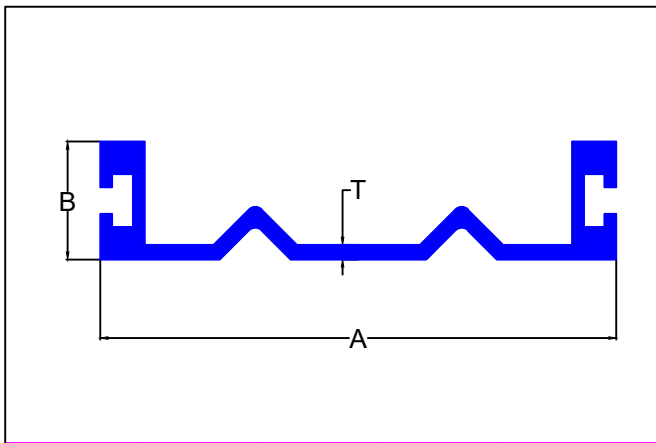

SEC.NO.	A	B	T	WT.Kg/mtr.
5320	175.00	40.00	5.00	4.614

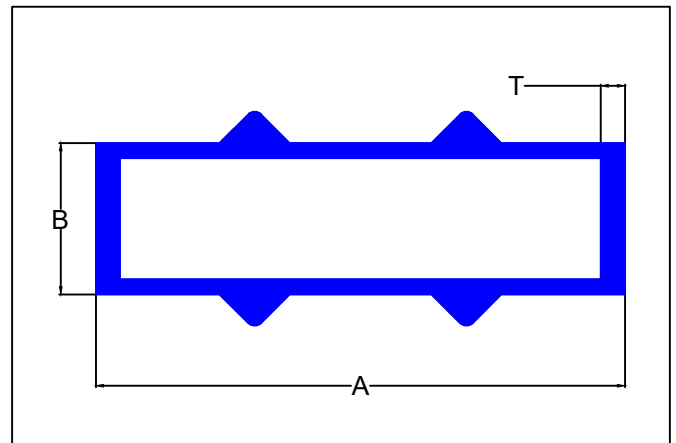

SEC.NO.	A	B	T	WT.Kg/mtr.
5321	175.00	50.00	8.00	7.881

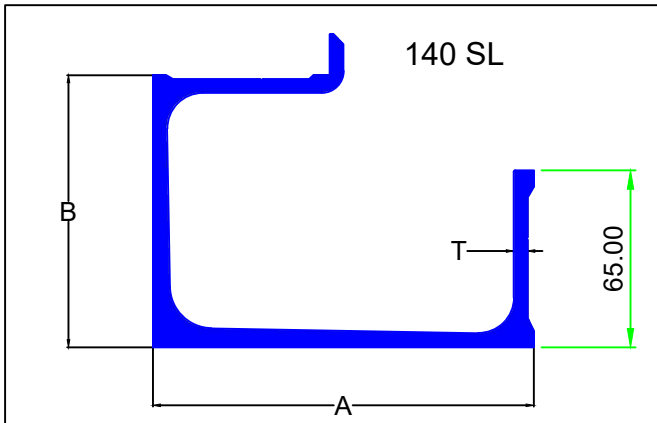

SEC.NO.	A	B	T	WT.Kg/mtr.
5322	140.00	100.00	5.00	6.019

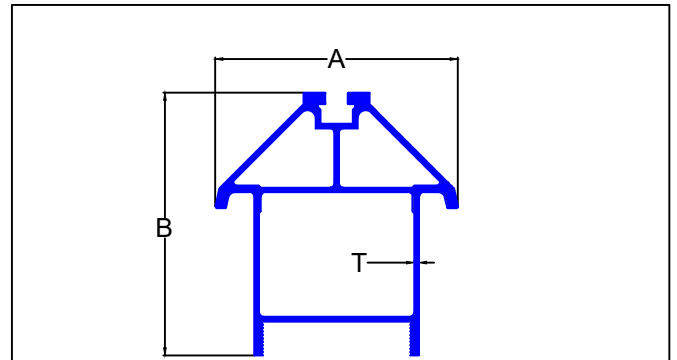

SEC.NO.	A	B	T	WT.Kg/mtr.
5326	148.50	160.85	3.00	6.765

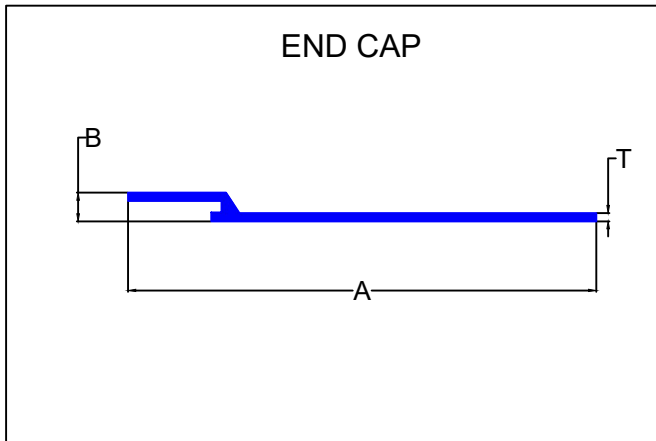

SEC.NO.	A	B	T	WT.Kg/mtr.
5327	225.18	13.75	4.00	2.631

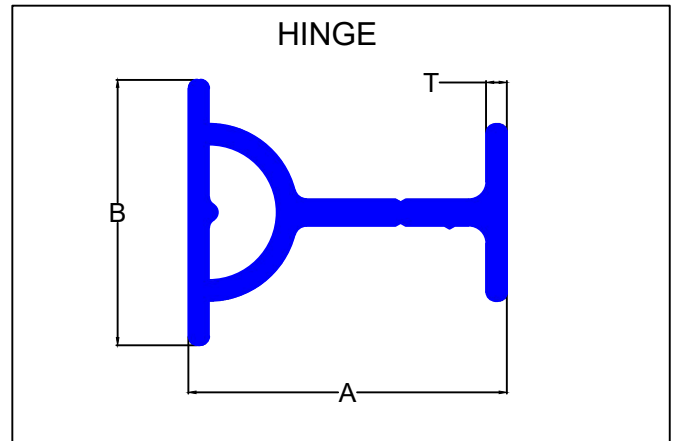

SEC.NO.	A	B	T	WT.Kg/mtr.
5328	54.00	45.00	3.50	1.504

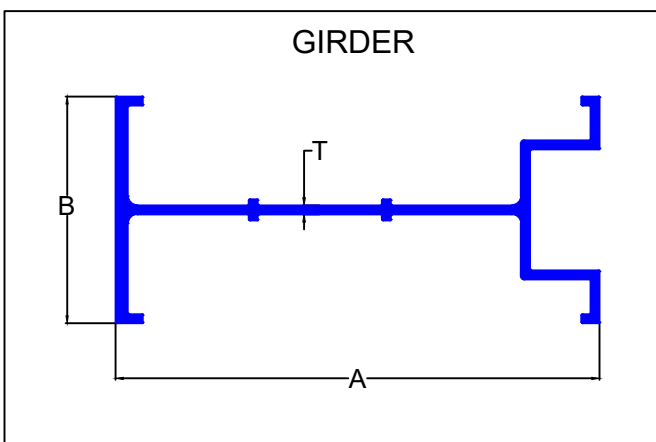

SEC.NO.	A	B	T	WT.Kg/mtr.
5329	160.00	75.00	3.00	3.057

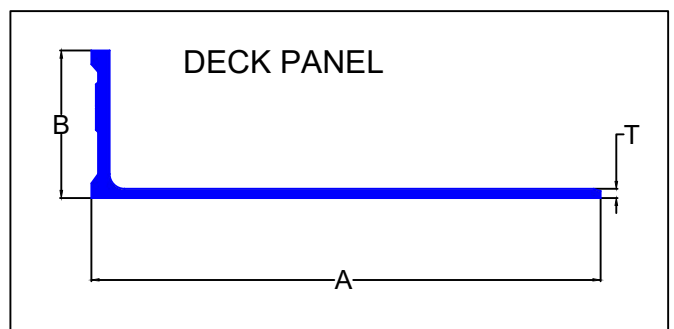

SEC.NO.	A	B	T	WT.Kg/mtr.
5330	224.50	65.00	4.00	3.424
5336	199.48	65.00	4.00	3.156
5337	174.48	65.00	4.00	2.886
5338	149.48	65.00	4.00	2.616

## GIRDER

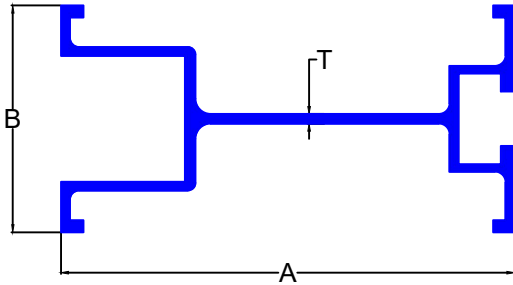

SEC.NO.	A	B	T	WT.Kg/mtr.
5331	150.00	75.00	3.20	3.308

## SB SECTION

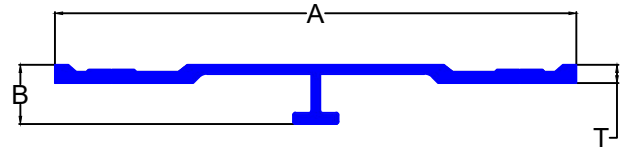

SEC.NO.	A	B	T	WT.Kg/mtr.
5332	230.00	26.00	8.00	3.619
5333	280.00	26.00	8.00	4.159

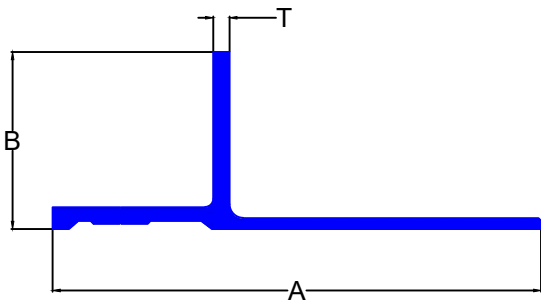

SEC.NO.	A	B	T	WT.Kg/mtr.
5334	179.50	65.00	6.00	3.244
5335	214.50	65.00	6.00	3.622

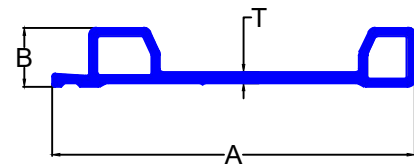

SEC.NO.	A	B	T	WT.Kg/mtr.
5340	123.00	20.00	3.80	1.843

## DECK PROP

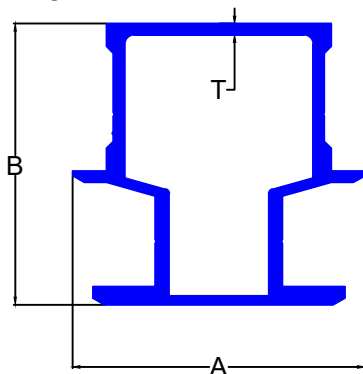

SEC.NO.	A	B	T	WT.Kg/mtr.
5341	129.00	124.00	5.00	7.474

## 124 SL

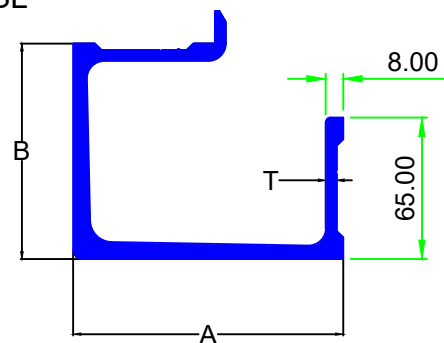

SEC.NO.	A	B	T	WT.Kg/mtr.
5342	124.00	99.00	5.00	6.280

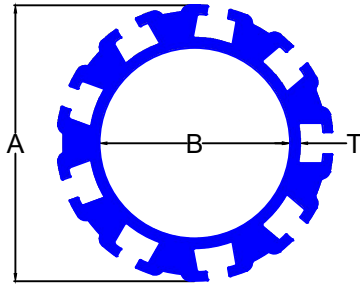

SEC.NO.	A	B	T	WT.Kg/mtr.
5344	152.00	105.00	5.50	16.007

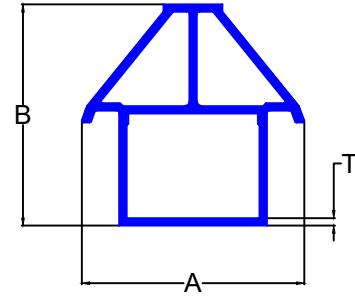

SEC.NO.	A	B	T	WT.Kg/mtr.
5345	150.80	150.00	5.00	9.121

### GIRDER

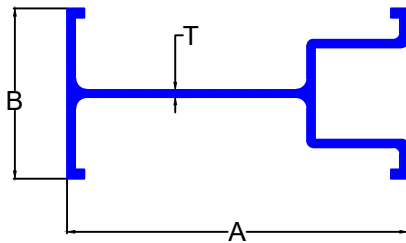

SEC.NO.	A	B	T	WT.Kg/mtr.
5346	150.00	75.00	3.20	3.241
5361	150.00	75.00	3.00	3.046

### END CAP

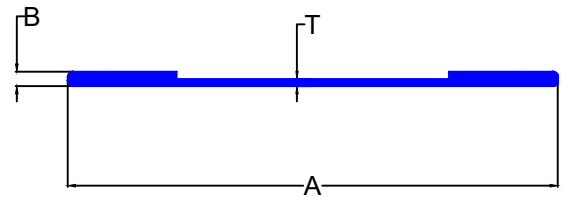

SEC.NO.	A	B	T	WT.Kg/mtr.
5347	245.00	8.00	4.00	3.920
5348	270.00	8.00	4.00	4.190

### SIDE RAIL

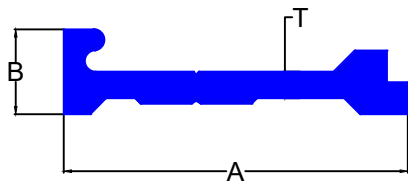

SEC.NO.	A	B	T	WT.Kg/mtr.
5349	65.00	16.00	5.00	1.263

### SIDE RAIL

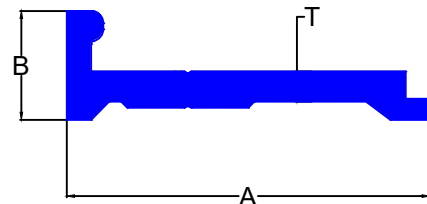

SEC.NO.	A	B	T	WT.Kg/mtr.
5350	60.00	18.00	5.00	1.060

## FLAT RAIL

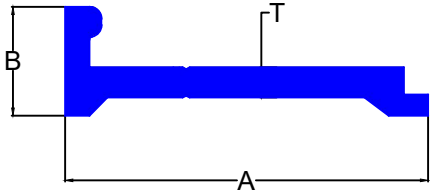

SEC.NO.	A	B	T	WT.Kg/mtr.
5351	60.00	18.00	5.00	1.004

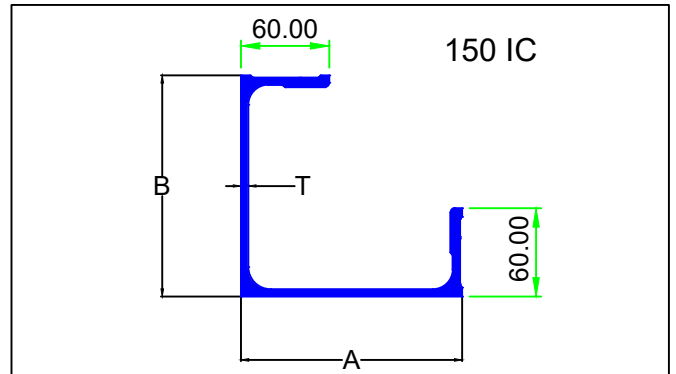

SEC.NO.	A	B	T	WT.Kg/mtr.
5352	150.00	150.00	5.00	6.121

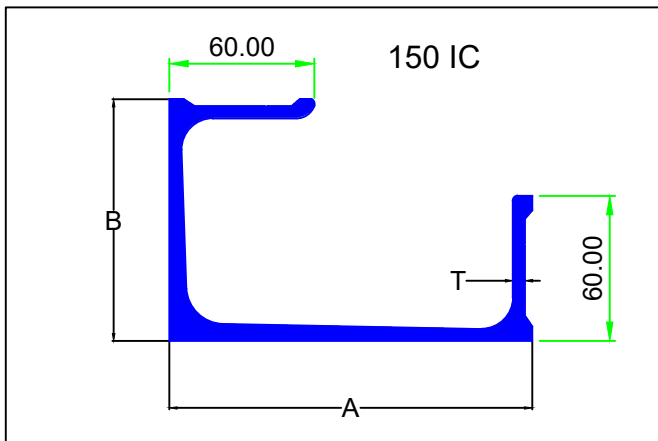

SEC.NO.	A	B	T	WT.Kg/mtr.
5353	150.00	100.00	5.00	5.887

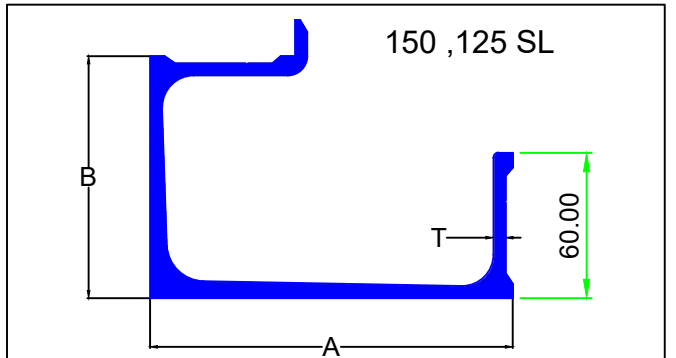

SEC.NO.	A	B	T	WT.Kg/mtr.
5354	150.00	100.00	5.00	6.173
5358	125.00	75.00	5.00	5.362

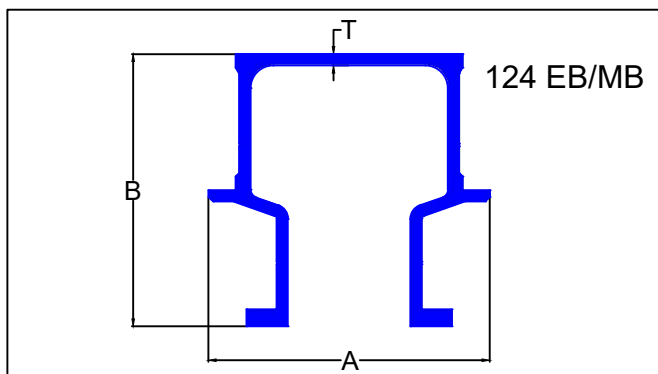

SEC.NO.	A	B	T	WT.Kg/mtr.
5355	124.00	120.00	5.00	5.840

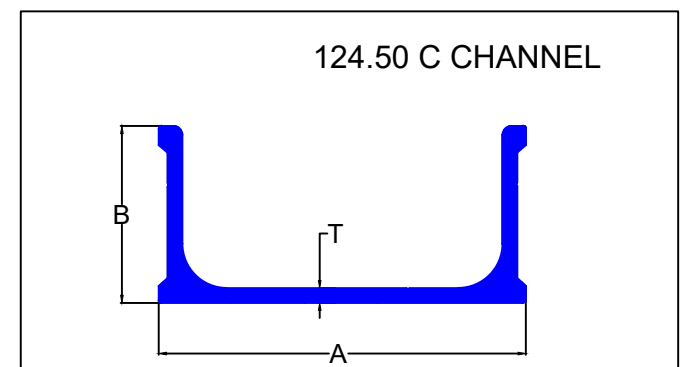

SEC.NO.	A	B	T	WT.Kg/mtr.
5356	124.50	60.00	5.00	3.572

DECK PANEL

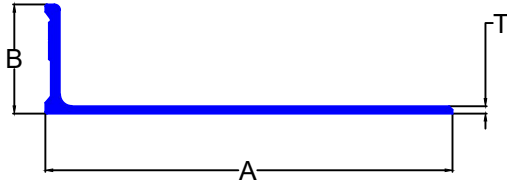

SEC.NO.	A	B	T	WT.Kg/mtr.
5357	224.50	60.00	4.00	3.328

C CHANNEL

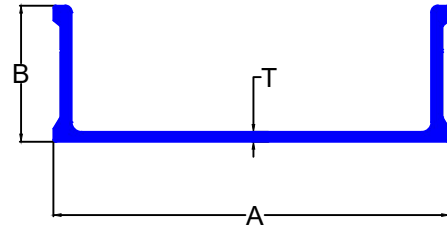

SEC.NO.	A	B	T	WT.Kg/mtr.
5359	174.50	60.00	4.30	3.728
5360	199.50	60.00	5.60	4.642

DECK PANEL

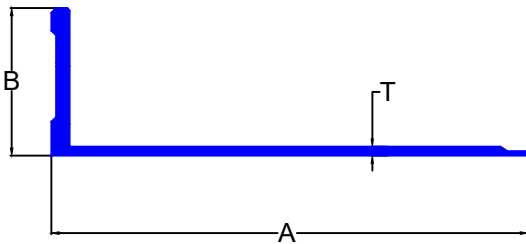

SEC.NO.	A	B	T	WT.Kg/mtr.
5362	210.00	65.00	4.00	3.316
5363	235.00	65.00	4.00	3.586
5364	260.00	65.00	4.00	3.857

C CHANNEL

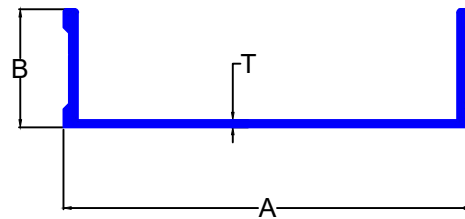

SEC.NO.	A	B	T	WT.Kg/mtr.
5365	200.00	65.00	5.00	4.678
5366	225.00	65.00	4.00	4.376
5367	250.00	65.00	4.00	4.648
5368	175.00	65.00	4.20	3.846
5369	200.00	65.00	4.20	4.130

FLAT RAIL

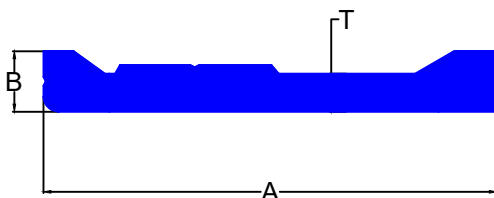

SEC.NO.	A	B	T	WT.Kg/mtr.
5370	60.00	8.00	5.00	0.987

129 EB/MB

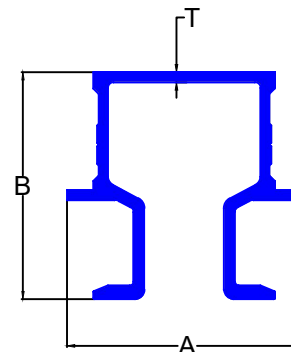

SEC.NO.	A	B	T	WT.Kg/mtr.
5372	129.00	125.00	5.70	7.278



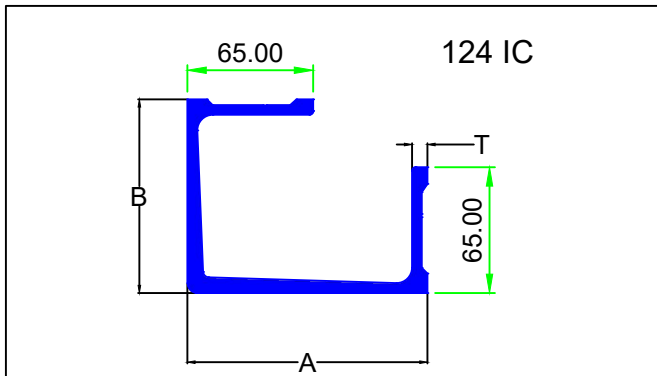

SEC.NO.	A	B	T	WT.Kg/mtr.
5373	124.00	99.00	8.00	5.672

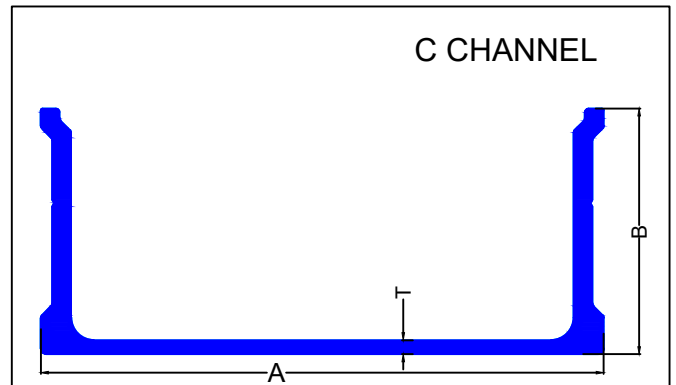

SEC.NO.	A	B	T	WT.Kg/mtr.
5374	149.00	65.00	3.70	3.330

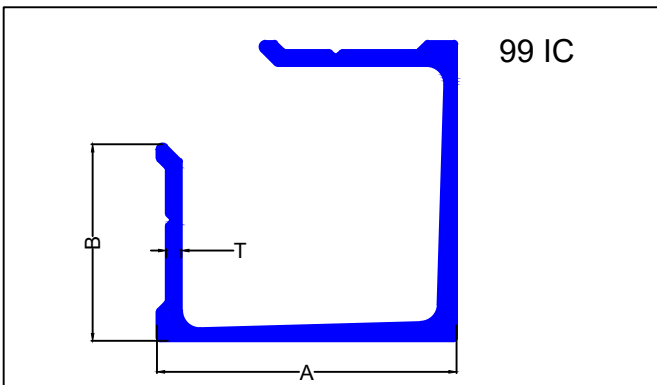

SEC.NO.	A	B	T	WT.Kg/mtr.
5375	99.00	65.00	5.00	4.420

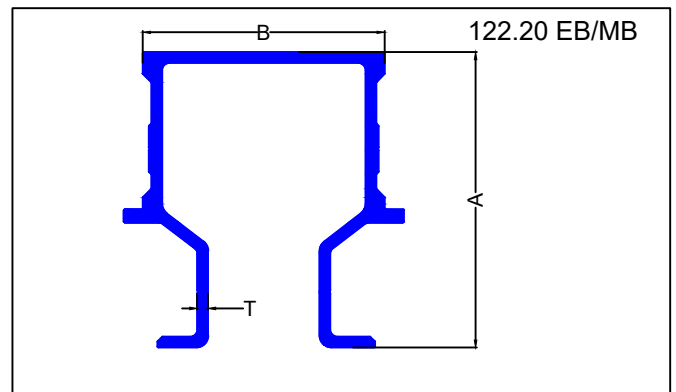

SEC.NO.	A	B	T	WT.Kg/mtr.
5376	122.20	100.00	4.50	5.430

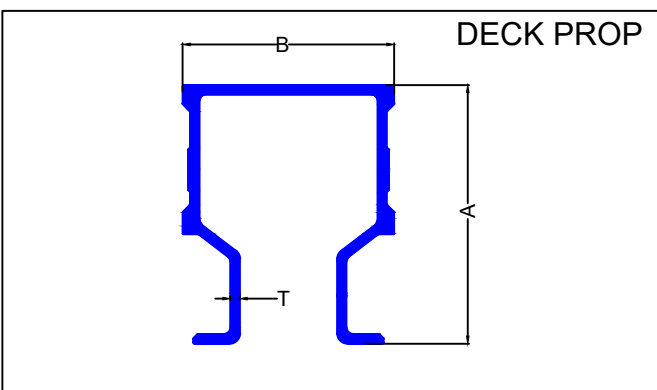

SEC.NO.	A	B	T	WT.Kg/mtr.
5377	122.20	100.00	4.50	5.190

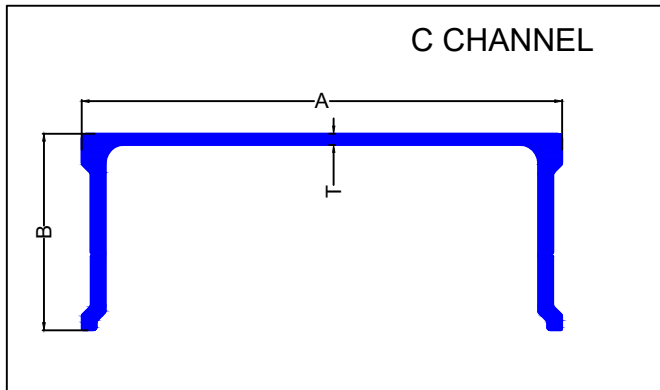

SEC.NO.	A	B	T	WT.Kg/mtr.
5379	159.00	65.00	3.70	3.438

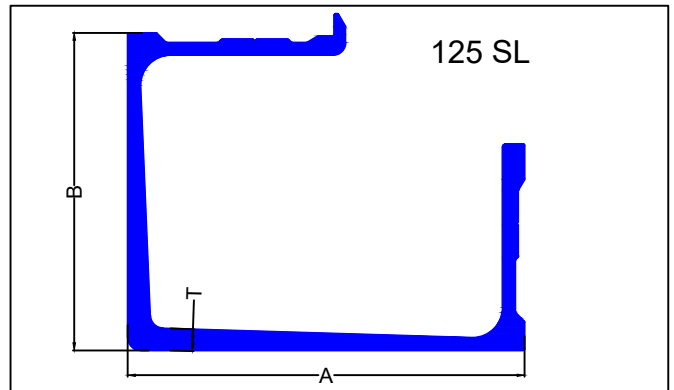

SEC.NO.	A	B	T	WT.Kg/mtr.
5380	125.00	100.00	7.00	5.056

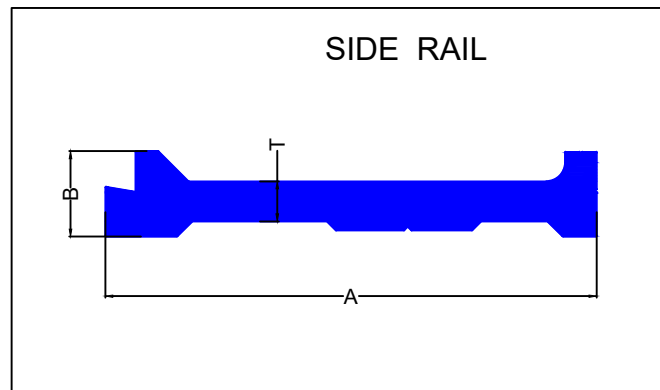

SEC.NO.	A	B	T	WT.Kg/mtr.
5381	65.00	11.30	5.30	1.168

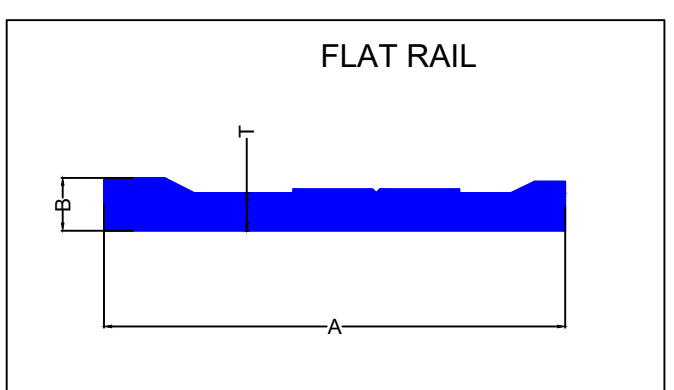

SEC.NO.	A	B	T	WT.Kg/mtr.
5382	61.00	7.00	5.00	0.929

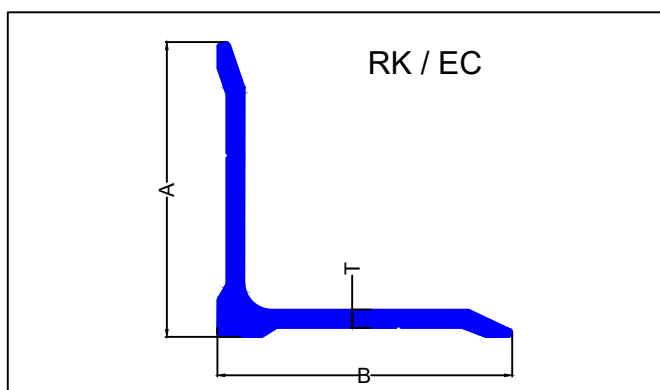

SEC.NO.	A	B	T	WT.Kg/mtr.
5383	65.00	65.00	4.00	1.427

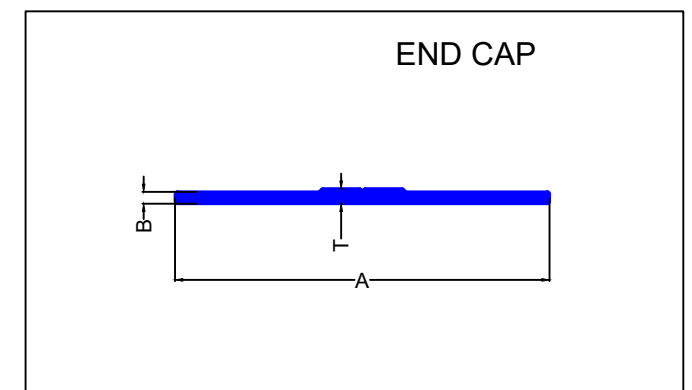

SEC.NO.	A	B	T	WT.Kg/mtr.
5384	99.00	3.20	4.00	0.900

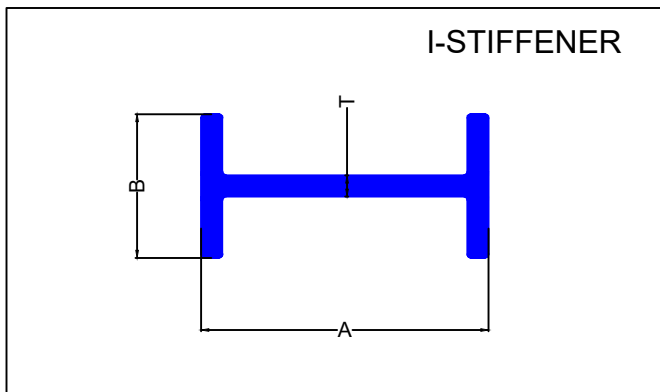

SEC.NO.	A	B	T	WT.Kg/mtr.
5385	38.00	19.00	2.80	0.531

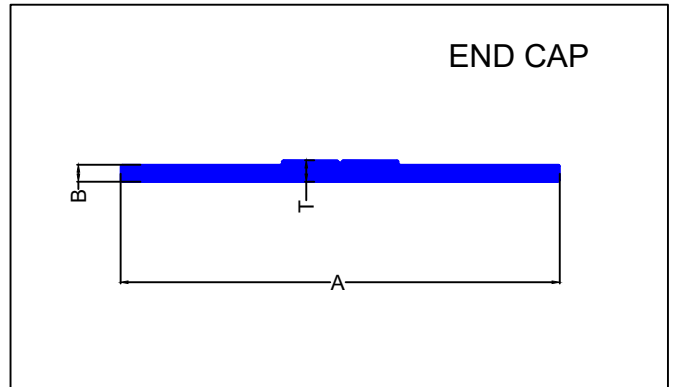

SEC.NO.	A	B	T	WT.Kg/mtr.
5386	83.00	3.20	4.00	0.763

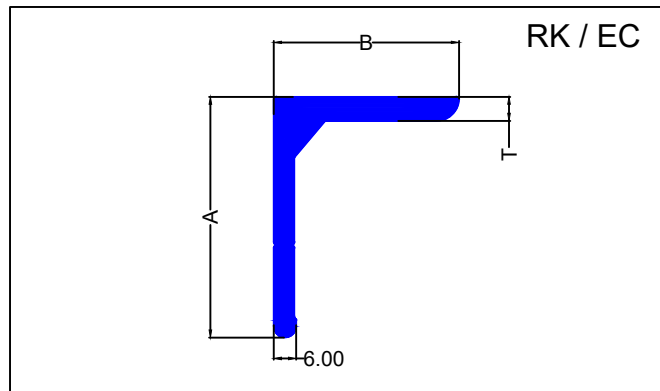

SEC.NO.	A	B	T	WT.Kg/mtr.
5387	65.00	50.00	6.50	1.835

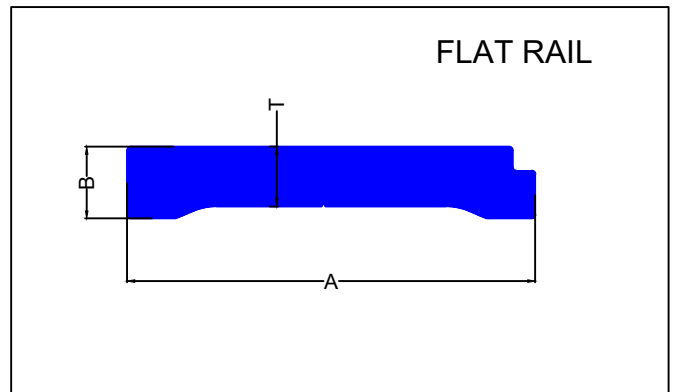

SEC.NO.	A	B	T	WT.Kg/mtr.
5388	54.00	9.50	7.90	1.197

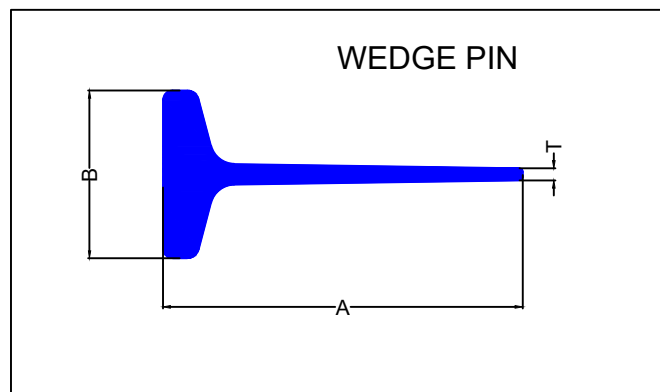

SEC.NO.	A	B	T	WT.Kg/mtr.
5389	47.60	22.20	1.60	0.595

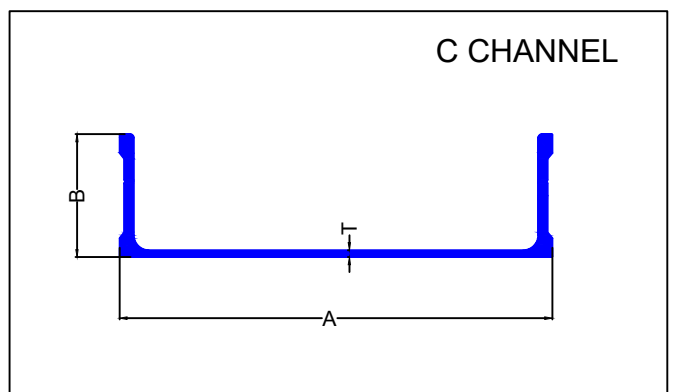

SEC.NO.	A	B	T	WT.Kg/mtr.
5390	229.00	65.00	3.60	4.212
5395	260.00	65.00	3.70	4.513

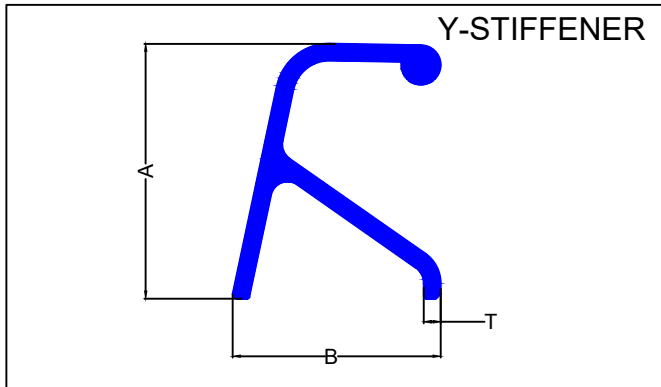

SEC.NO.	A	B	T	WT.Kg/mtr.
5391	52.70	43.00	3.50	1.271

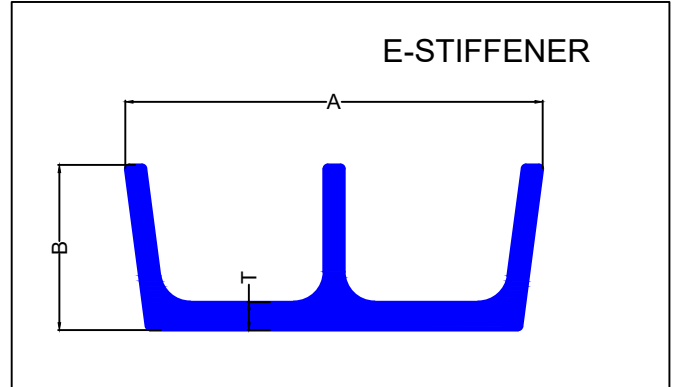

SEC.NO.	A	B	T	WT.Kg/mtr.
5392	55.20	21.85	3.70	0.930

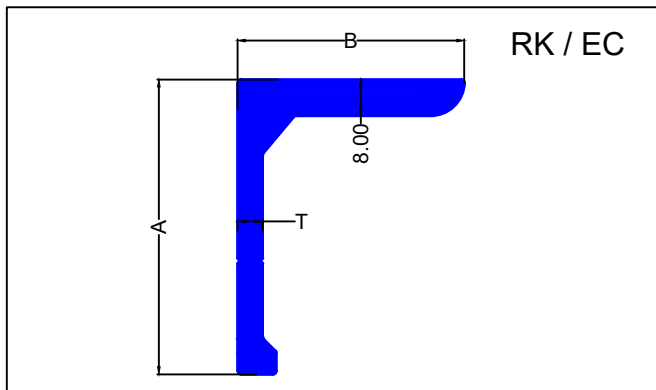

SEC.NO.	A	B	T	WT.Kg/mtr.
5393	65.00	49.97	5.50	2.022

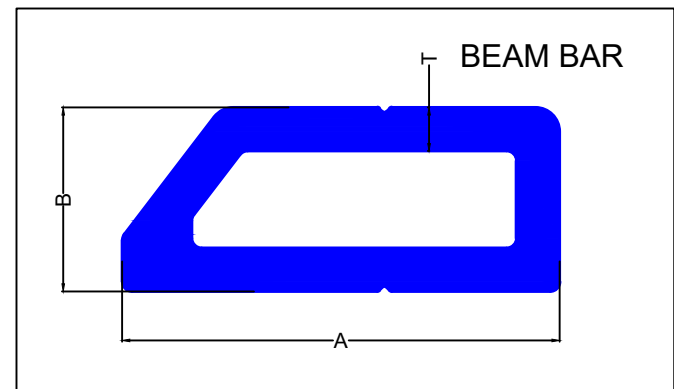

SEC.NO.	A	B	T	WT.Kg/mtr.
5394	45.20	19.00	4.50	1.272

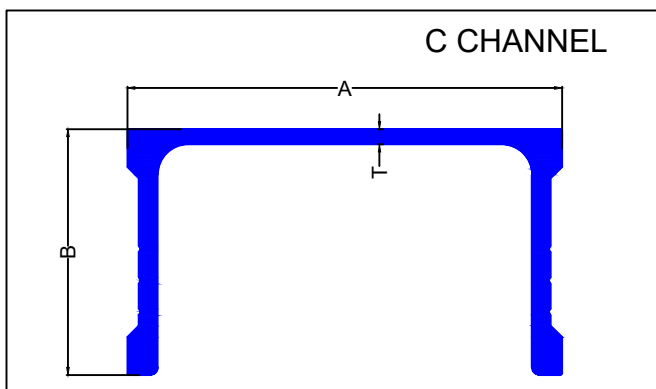

SEC.NO.	A	B	T	WT.Kg/mtr.
5396	115.00	65.00	4.00	3.258

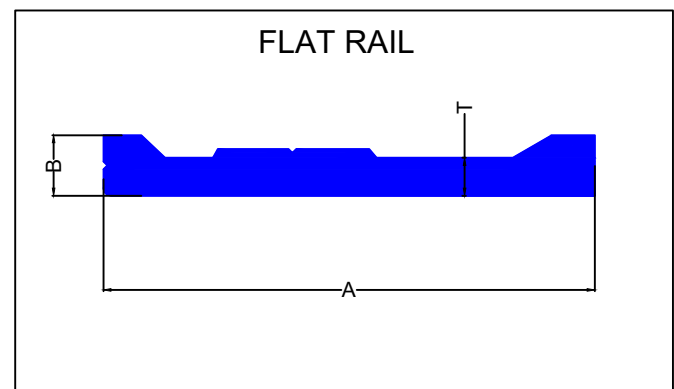

SEC.NO.	A	B	T	WT.Kg/mtr.
5397	65.00	8.00	5.00	1.060

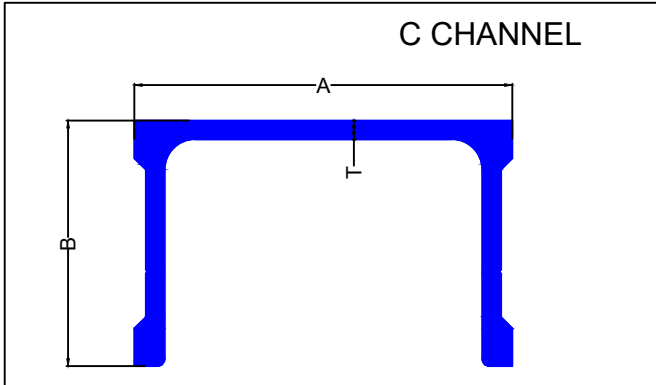

SEC.NO.	A	B	T	WT.Kg/mtr.
5398	100.00	65.00	5.00	3.329

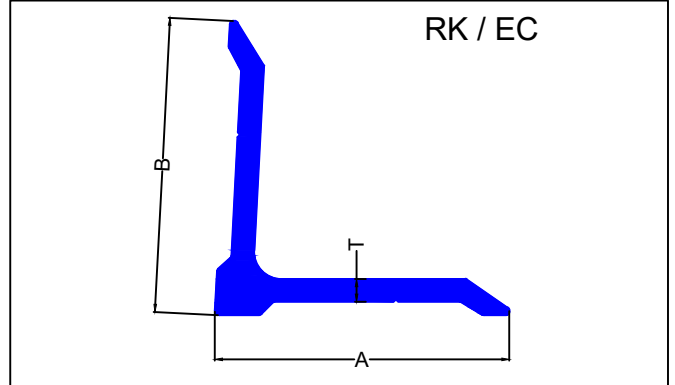

SEC.NO.	A	B	T	WT.Kg/mtr.
5399	65.00	65.00	5.00	1.747

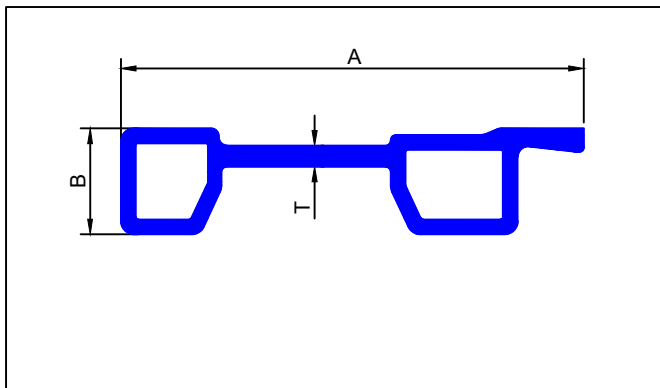

SEC.NO.	A	B	T	WT.Kg/mtr.
5400	87.50	20.00	4.00	1.500

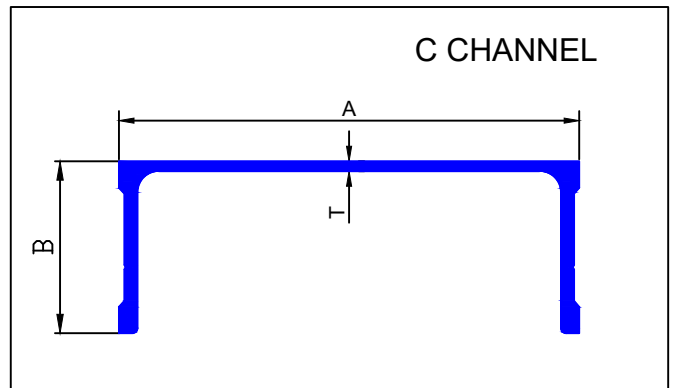

SEC.NO.	A	B	T	WT.Kg/mtr.
5401	174.00	65.00	3.70	3.660

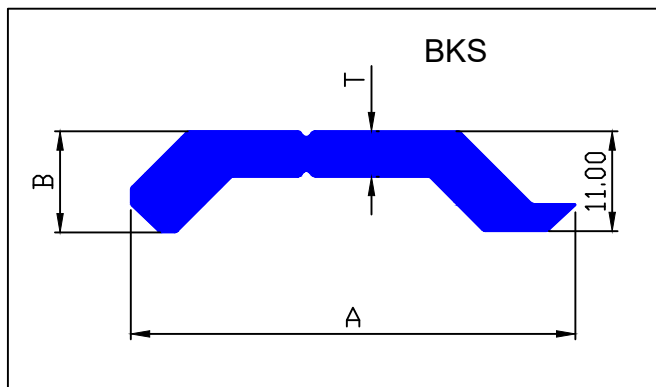

SEC.NO.	A	B	T	WT.Kg/mtr.
5402	49.00	11.15	5.00	0.737

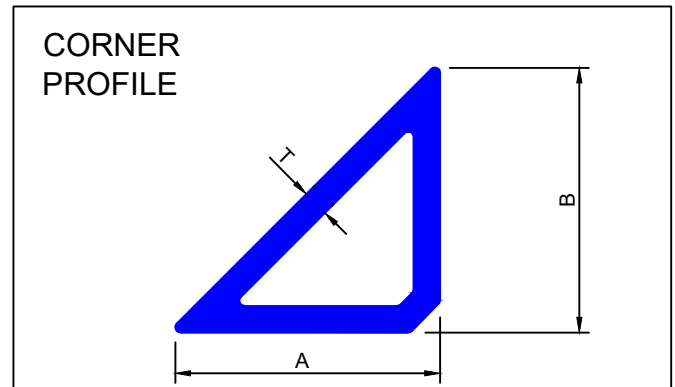

SEC.NO.	A	B	T	WT.Kg/mtr.
5403	25.00	25.00	2.50	0.485

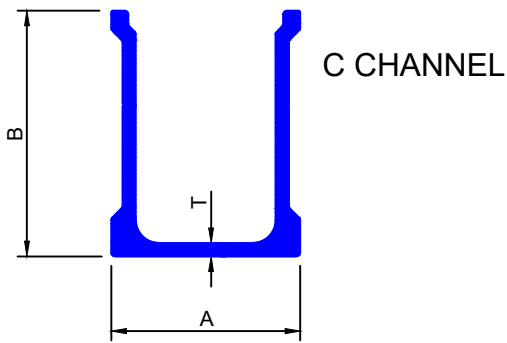

SEC.NO.	A	B	T	WT.Kg/mtr.
5404	50.00	65.00	3.50	1.855
5405	55.00	65.00	3.50	1.903
5406	75.00	65.00	3.50	2.092

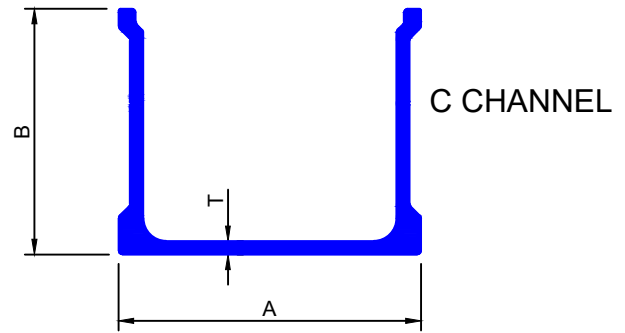

SEC.NO.	A	B	T	WT.Kg/mtr.
5407	80.00	65.00	3.50	2.139
5409	105.00	65.00	3.50	2.375

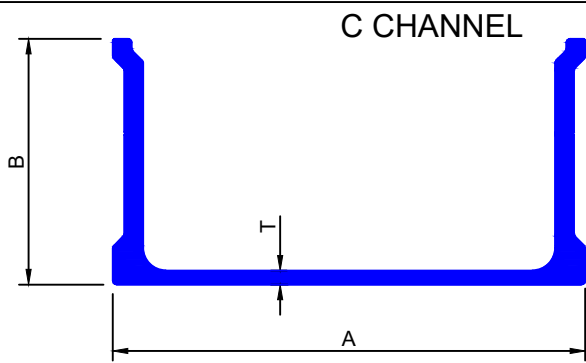

SEC.NO.	A	B	T	WT.Kg/mtr.
5412	125.00	65.00	3.70	3.100

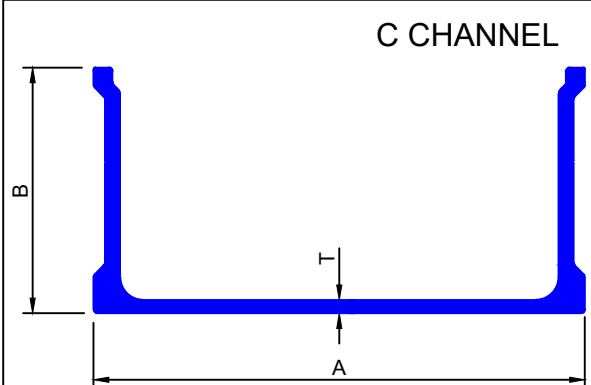

SEC.NO.	A	B	T	WT.Kg/mtr.
5413	130.00	65.00	3.50	2.772

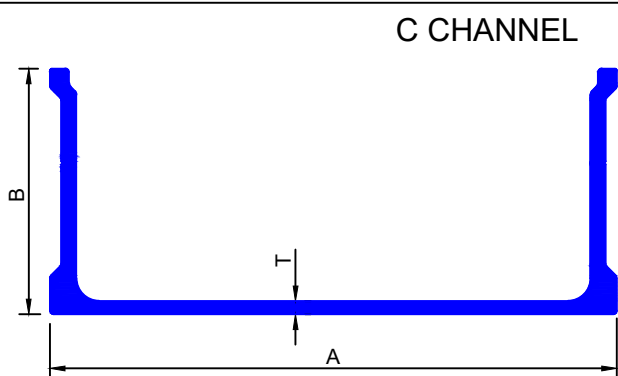

SEC.NO.	A	B	T	WT.Kg/mtr.
5416	150.00	65.00	3.50	2.961
5419	160.00	65.00	3.50	3.055

### IC PROFILES

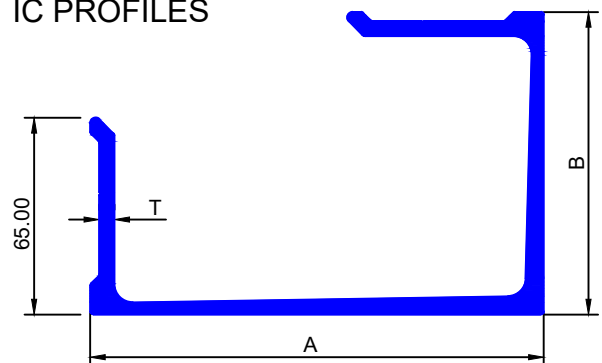

SEC.NO.	A	B	T	WT.Kg/mtr.
5417	150.00	100.00	5.00	5.122
5420	160.00	100.00	5.00	5.289
5423	170.00	100.00	5.00	5.460

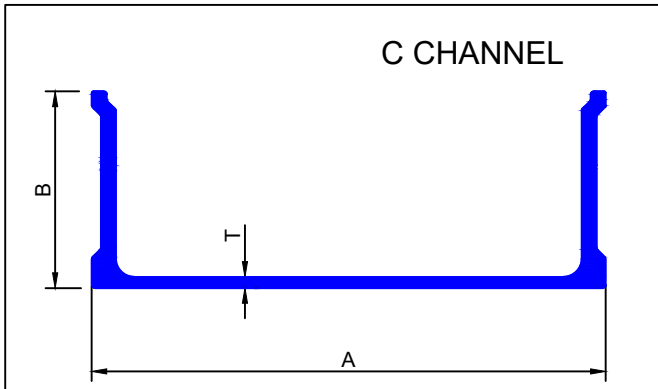

SEC.NO.	A	B	T	WT.Kg/mtr.
5422	170.00	65.00	3.70	3.550
5424	175.00	65.00	3.70	3.600
5425	180.00	65.00	3.70	3.650
5427	190.00	65.00	3.70	3.750
5429	200.00	65.00	3.70	3.850

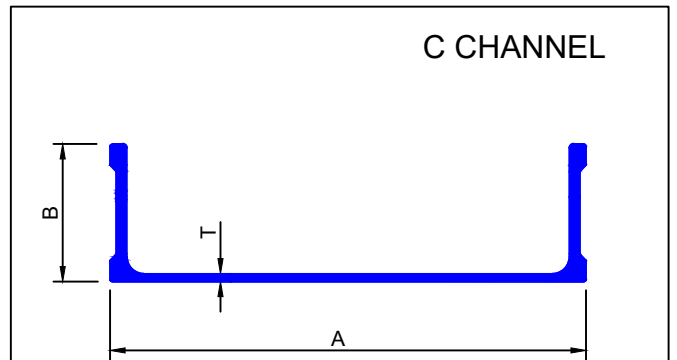

SEC.NO.	A	B	T	WT.Kg/mtr.
5430	225.00	65.00	3.70	4.280
5431	230.00	65.00	3.70	4.330
5432	240.00	65.00	3.70	4.430
5433	250.00	65.00	3.70	4.530

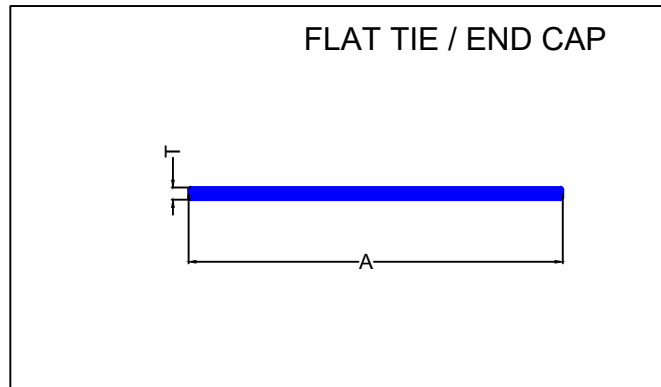

SEC.NO.	A	B	T	WT.Kg/mtr.
5434	99.00	-----	3.20	0.854

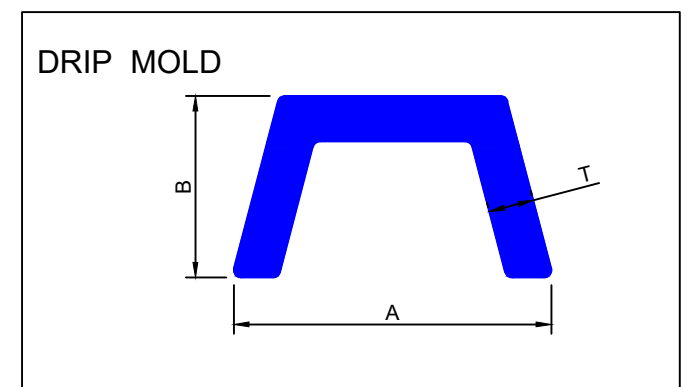

SEC.NO.	A	B	T	WT.Kg/mtr.
5435	21.00	12.00	3.00	0.277

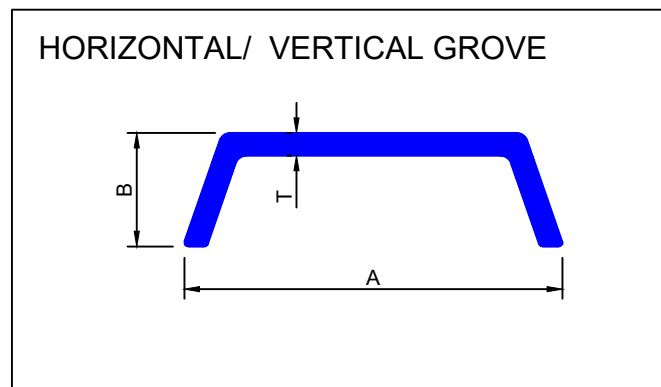

SEC.NO.	A	B	T	WT.Kg/mtr.
5436	50.00	15.00	3.00	0.537

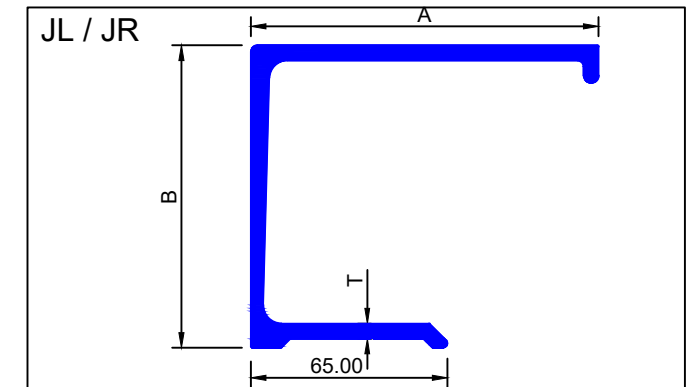

SEC.NO.	A	B	T	WT.Kg/mtr.
5437	115.00	100.00	5.00	3.848

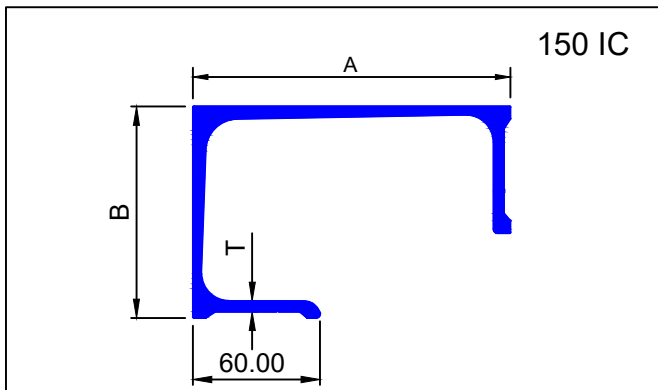

SEC.NO.	A	B	T	WT.Kg/mtr.
5438	150.00	100.00	5.00	5.273

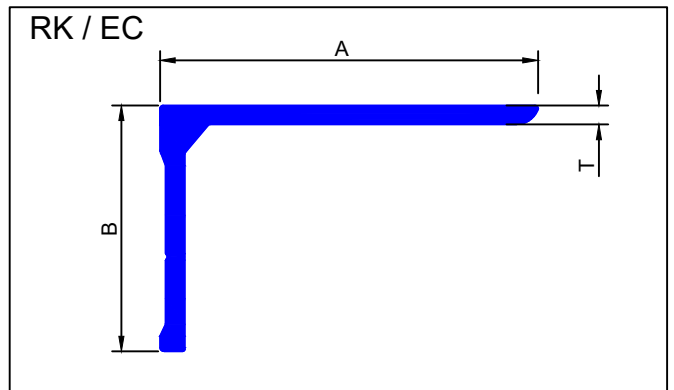

SEC.NO.	A	B	T	WT.Kg/mtr.
5439	100.00	65.00	5.00	2.264
5440	125.00	65.00	5.00	2.602

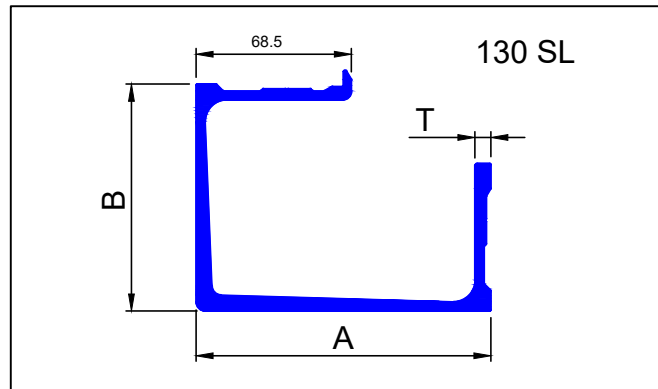

SEC.NO.	A	B	T	WT.Kg/mtr.
5442	130.00	100.00	7.00	5.130

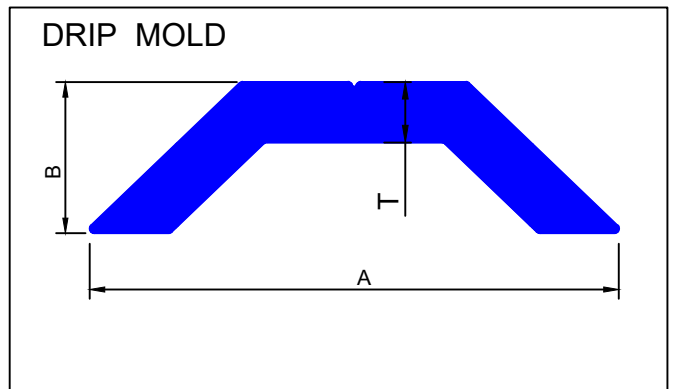

SEC.NO.	A	B	T	WT.Kg/mtr.
5443	35.00	10.00	4.00	0.393

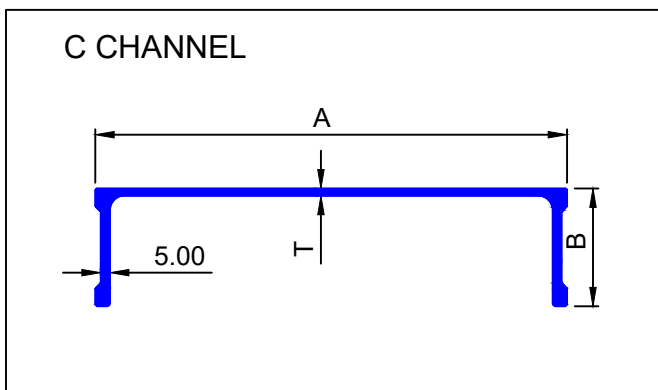

SEC.NO.	A	B	T	WT.Kg/mtr.
5444	260.00	65.00	4.00	4.827
5445	240.00	65.00	4.00	4.611
5446	230.00	65.00	4.00	4.503

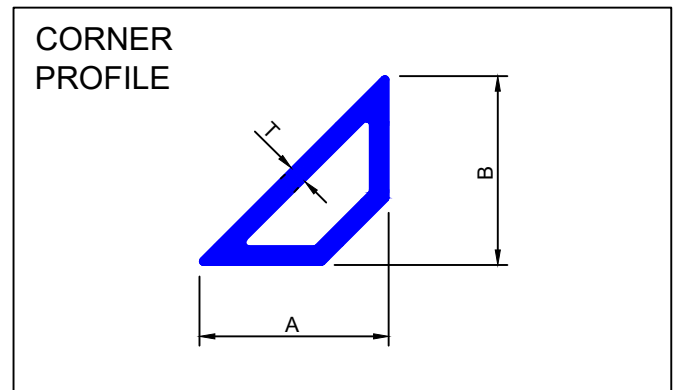

SEC.NO.	A	B	T	WT.Kg/mtr.
5447	25.00	25.00	2.50	0.462



DRIP MOLD

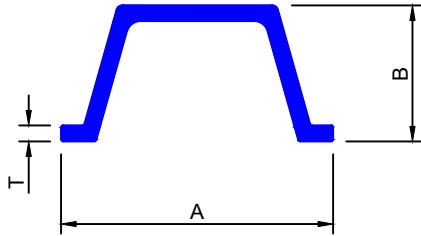

SEC.NO.	A	B	T	WT.Kg/mtr.
5448	60.00	30.00	3.50	0.949

SB FLAT

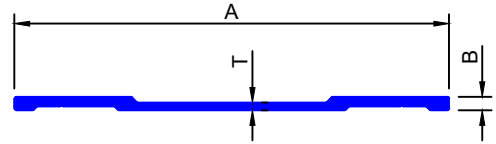

SEC.NO.	A	B	T	WT.Kg/mtr.
5449	230.00	7.00	4.00	3.043
5467	210.00	7.00	4.00	2.827

HORIZONTAL/ VERTICAL GROVE

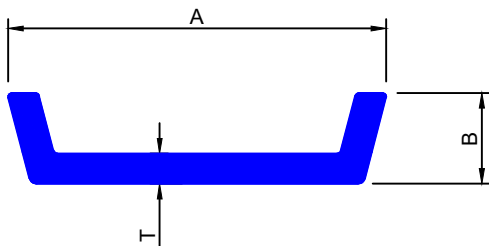

SEC.NO.	A	B	T	WT.Kg/mtr.
5452	50.00	12.00	4.00	0.664

DECK PANEL

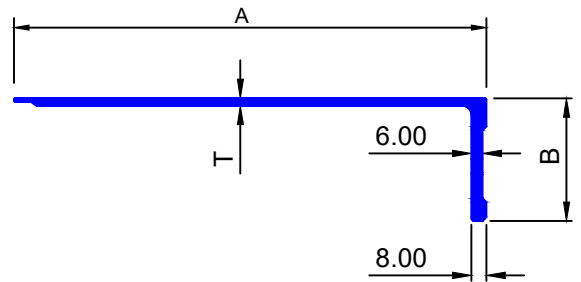

SEC.NO.	A	B	T	WT.Kg/mtr.
5453	250.00	65.00	4.00	3.761

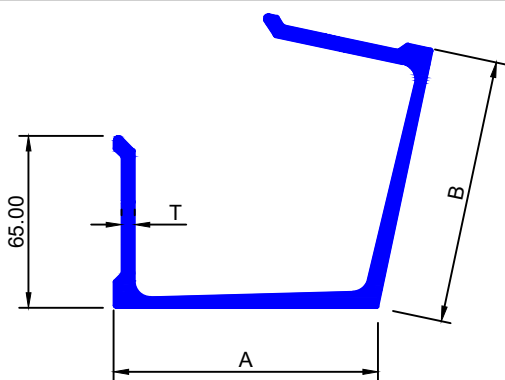

SEC.NO.	A	B	T	WT.Kg/mtr.
5454	100.00	100.00	5.00	4.460

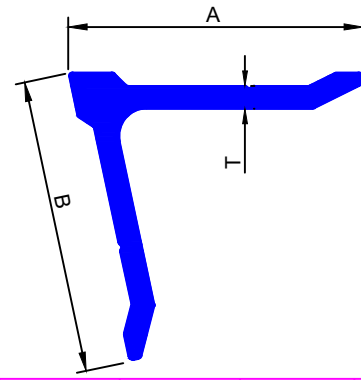

SEC.NO.	A	B	T	WT.Kg/mtr.
5455	65.00	65.00	5.00	1.744

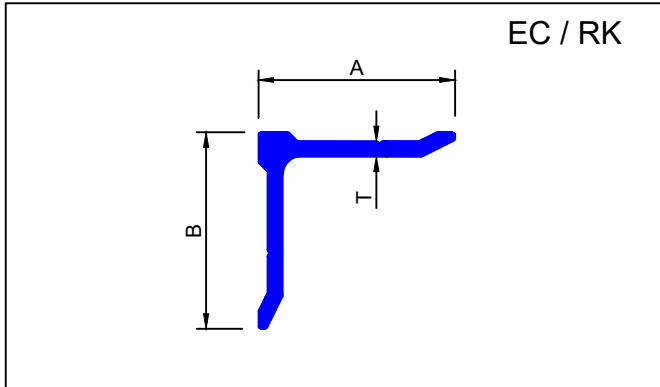

SEC.NO.	A	B	T	WT.Kg/mtr.
5456	65.00	65.00	5.00	1.772

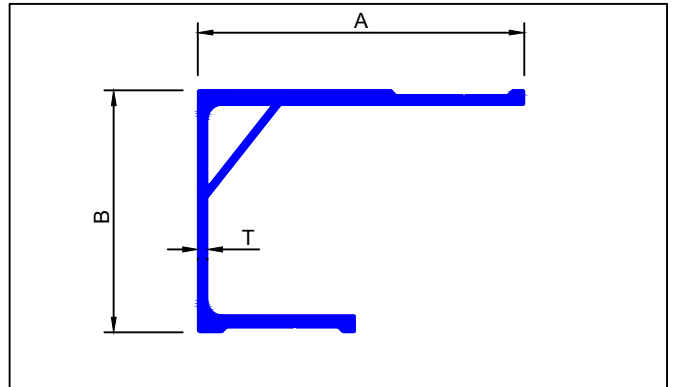

SEC.NO.	A	B	T	WT.Kg/mtr.
5457	135.00	100.00	4.00	4.174
5458	125.00	100.00	4.00	4.057
5459	115.00	100.00	4.00	3.895
5460	105.00	100.00	4.00	3.733
5461	95.00	100.00	4.00	3.610
5462	85.00	100.00	4.00	3.448

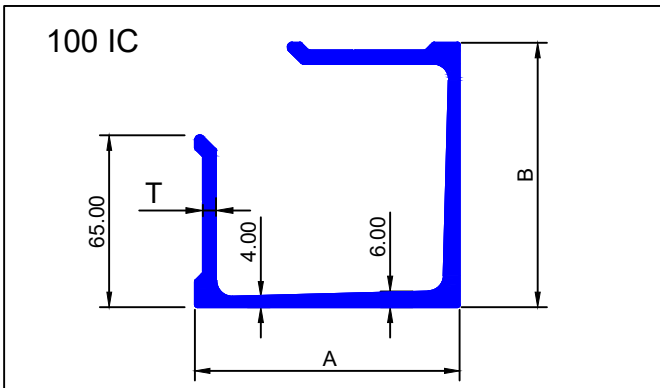

SEC.NO.	A	B	T	WT.Kg/mtr.
5463	100.00	100.00	5.00	4.447

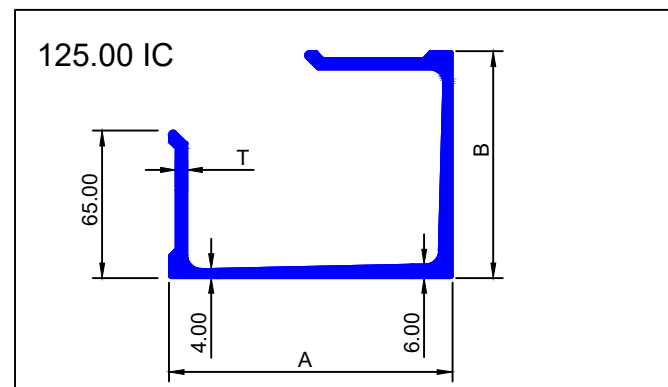

SEC.NO.	A	B	T	WT.Kg/mtr.
5464	125.00	100.00	5.00	4.785

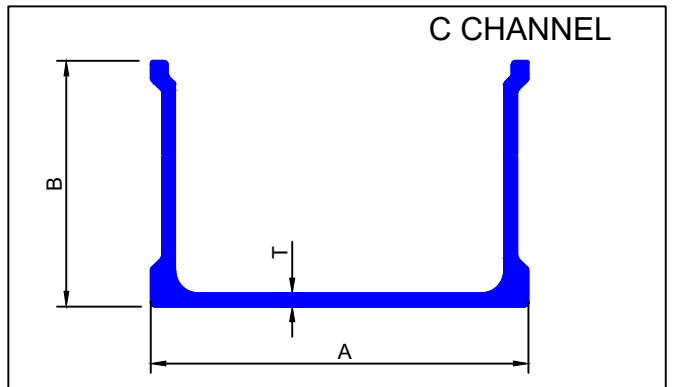

SEC.NO.	A	B	T	WT.Kg/mtr.
5465	100.00	65.00	3.50	2.328

C CHANNEL

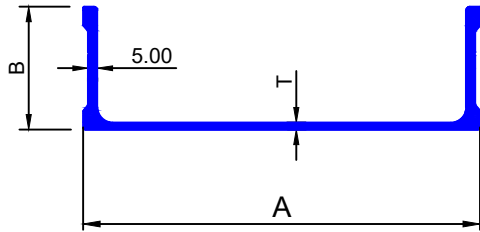

SEC.NO.	A	B	T	WT.Kg/mtr.
5466	210.00	65.00	3.70	4.079

STIFFENER

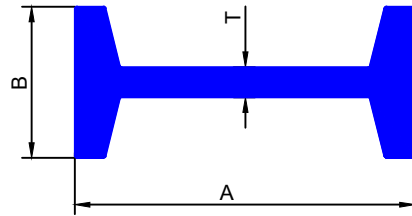

SEC.NO.	A	B	T	WT.Kg/mtr.
5468	45.00	20.00	4.00	0.917

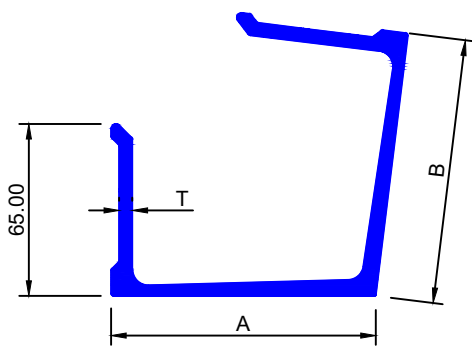

SEC.NO.	A	B	T	WT.Kg/mtr.
5469	100.00	100.00	5.00	4.455

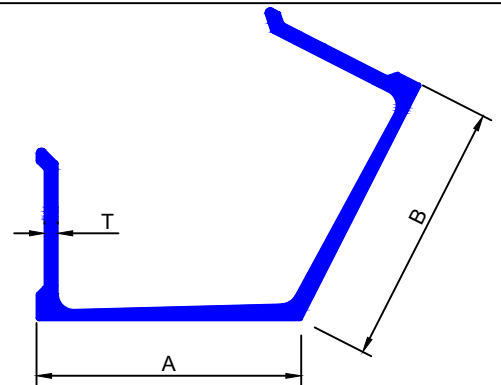

SEC.NO.	A	B	T	WT.Kg/mtr.
5470	100.00	100.00	5.00	4.474

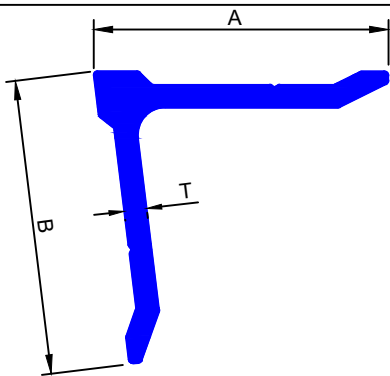

SEC.NO.	A	B	T	WT.Kg/mtr.
5471	65.00	65.00	5.00	1.756

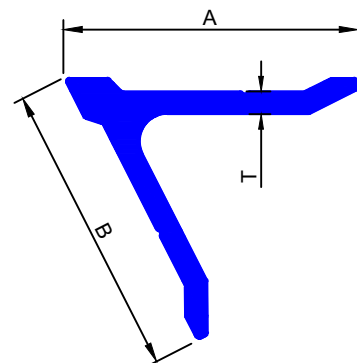

SEC.NO.	A	B	T	WT.Kg/mtr.
5472	65.00	65.00	5.00	1.701

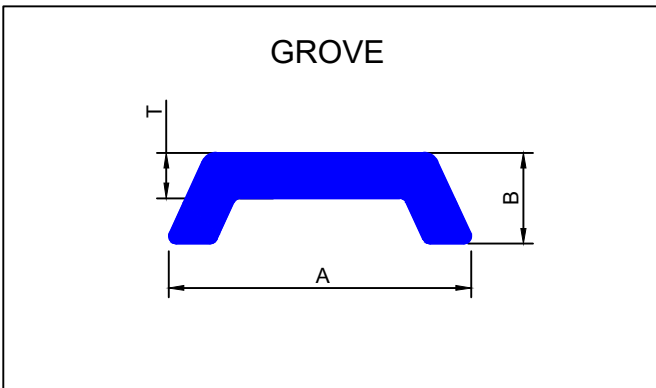

SEC.NO.	A	B	T	WT.Kg/mtr.
5473	20.00	6.00	3.00	0.185

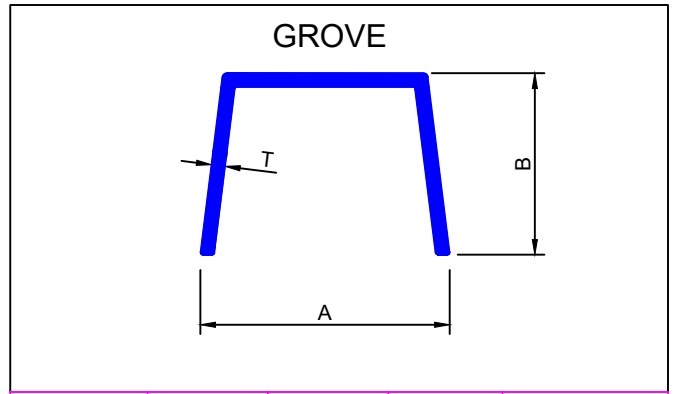

SEC.NO.	A	B	T	WT.Kg/mtr.
5474	55.00	40.00	3.00	0.970

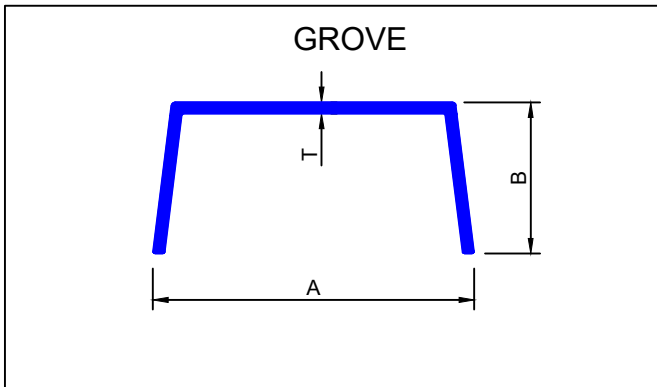

SEC.NO.	A	B	T	WT.Kg/mtr.
5475	85.00	40.00	3.00	1.213

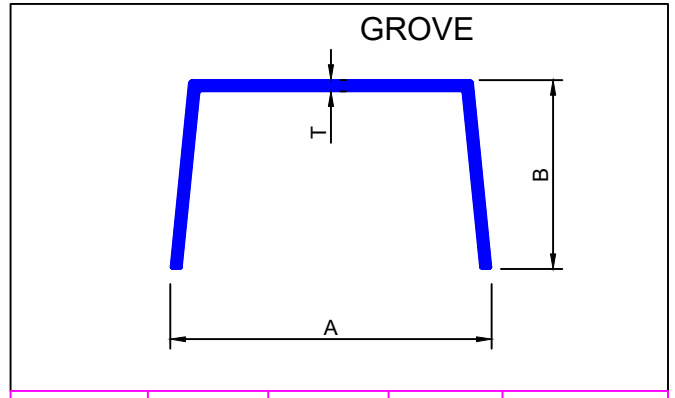

SEC.NO.	A	B	T	WT.Kg/mtr.
5476	85.00	50.00	3.00	1.373

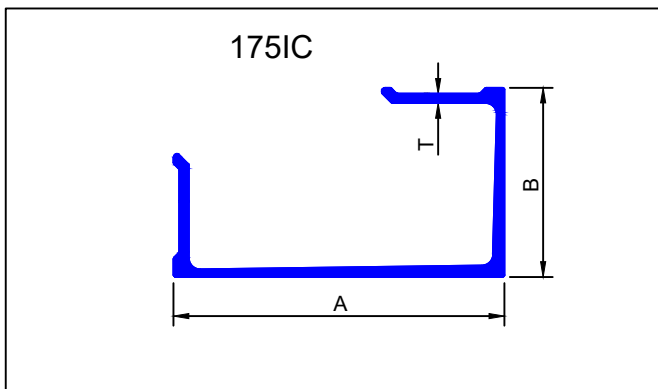

SEC.NO.	A	B	T	WT.Kg/mtr.
5477	175.00	100.00	5.00	5.460

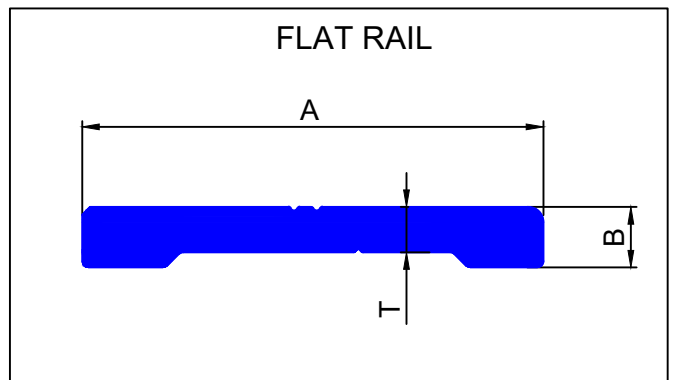

SEC.NO.	A	B	T	WT.Kg/mtr.
5478	61.00	8.00	6.00	1.105

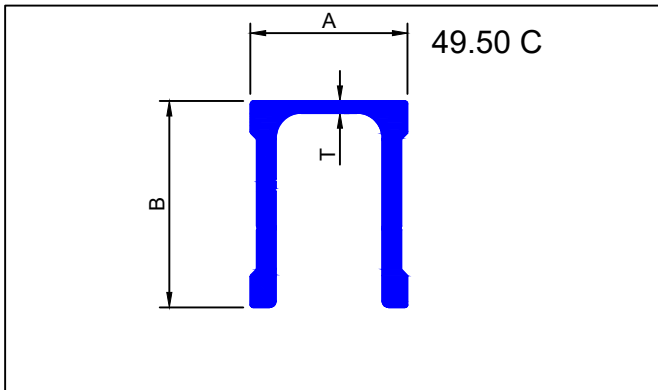

SEC.NO.	A	B	T	WT.Kg/mtr.
5479	49.50	65.00	3.80	2.751

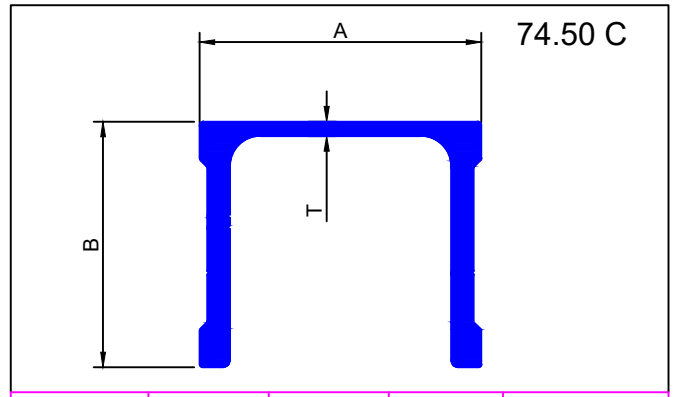

SEC.NO.	A	B	T	WT.Kg/mtr.
5480	74.50	65.00	3.80	3.008

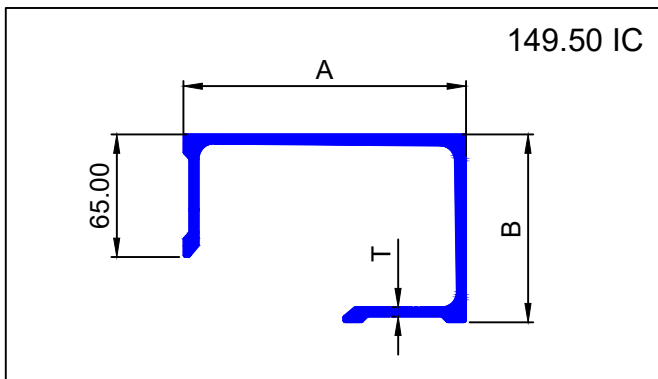

SEC.NO.	A	B	T	WT.Kg/mtr.
5481	149.50	99.50	5.00	5.530

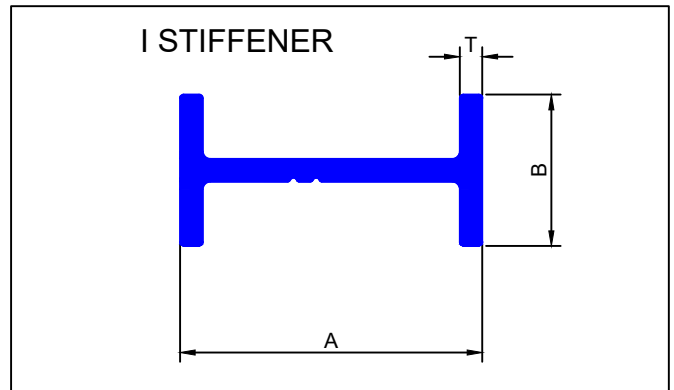

SEC.NO.	A	B	T	WT.Kg/mtr.
5482	40.00	20.00	3.00	0.598

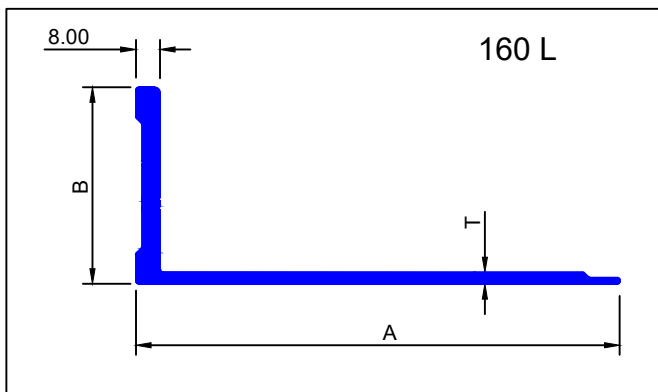

SEC.NO.	A	B	T	WT.Kg/mtr.
5483	160.00	65.00	3.80	2.671

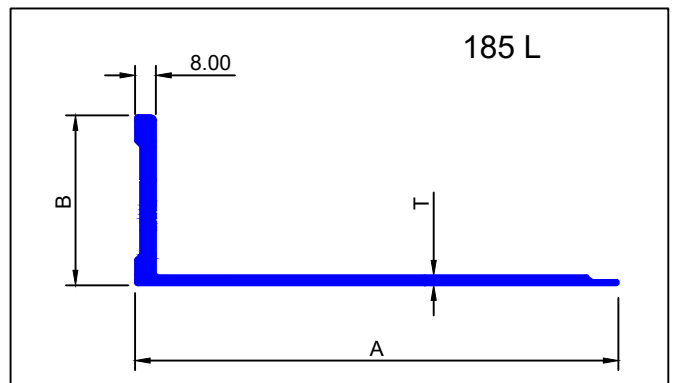

SEC.NO.	A	B	T	WT.Kg/mtr.
5484	185.00	65.00	3.80	2.927

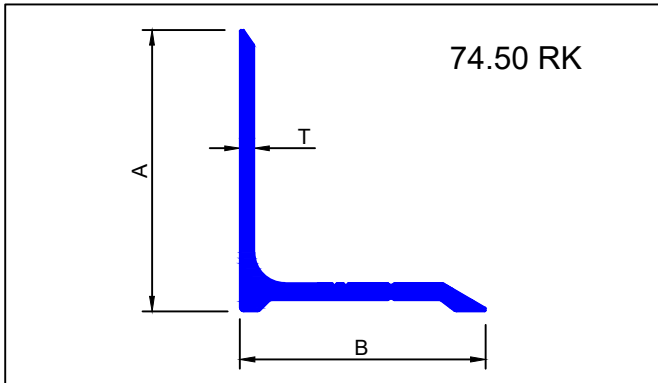

SEC.NO.	A	B	T	WT.Kg/mtr.
5485	74.50	65.00	3.80	1.529

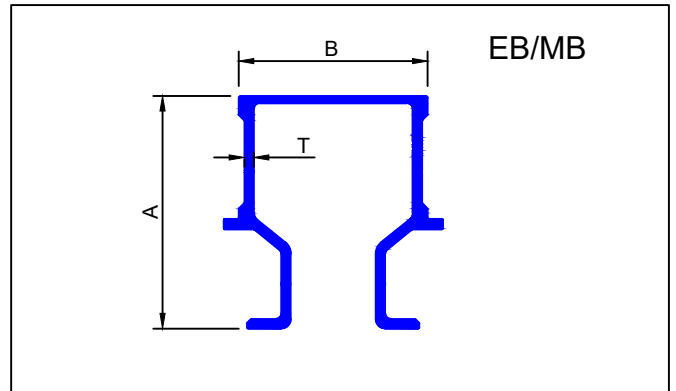

SEC.NO.	A	B	T	WT.Kg/mtr.
5486	123.00	100.00	5.00	5.571

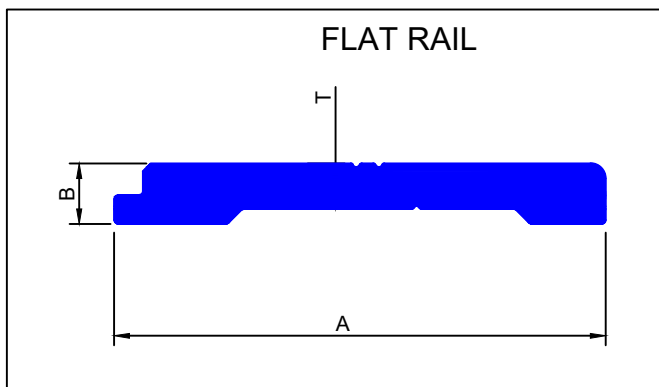

SEC.NO.	A	B	T	WT.Kg/mtr.
5487	65.00	8.00	6.00	1.148

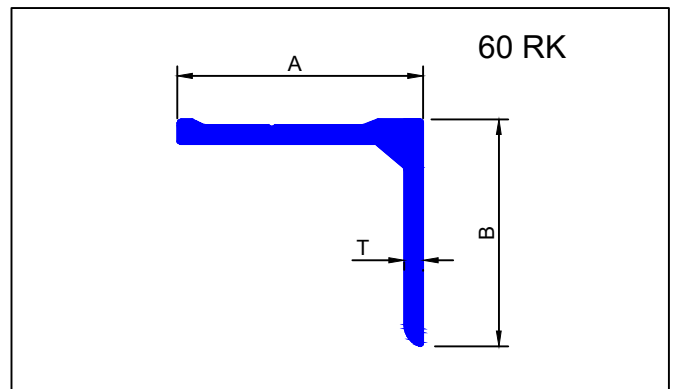

SEC.NO.	A	B	T	WT.Kg/mtr.
5488	65.00	60.00	5.00	1.724

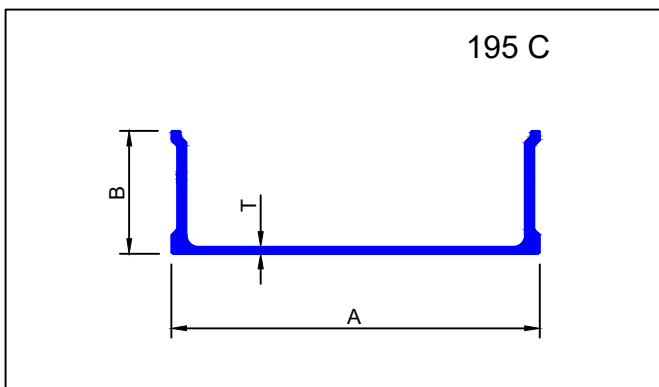

SEC.NO.	A	B	T	WT.Kg/mtr.
5489	195.00	65.00	3.70	3.800

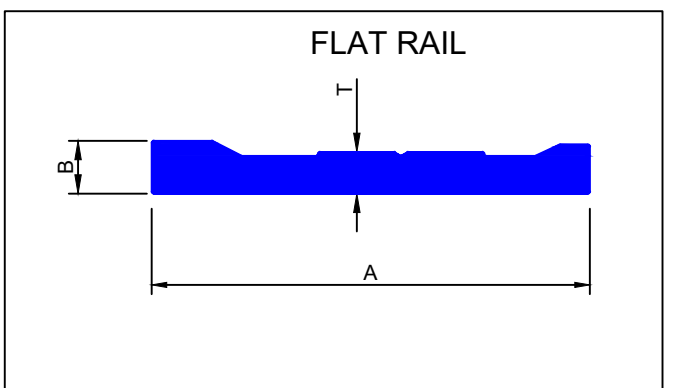

SEC.NO.	A	B	T	WT.Kg/mtr.
5490	58.00	7.00	5.50	0.887

END CAP

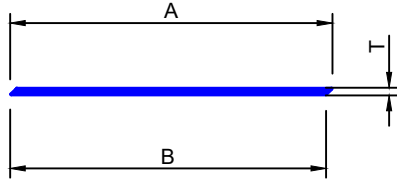

SEC.NO.	A	B	T	WT.Kg/mtr.
5491	142.09	139.29	3.50	1.321

185 C

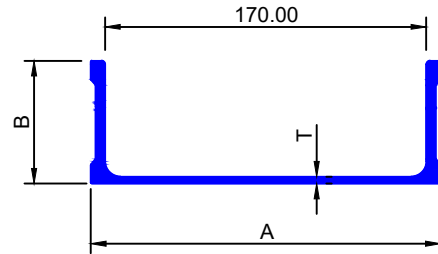

SEC.NO.	A	B	T	WT.Kg/mtr.
5492	185.00	65.00	3.70	3.832

120IC

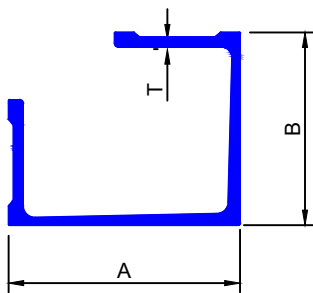

SEC.NO.	A	B	T	WT.Kg/mtr.
5493	120.00	100.00	5.00	4.824

180IC

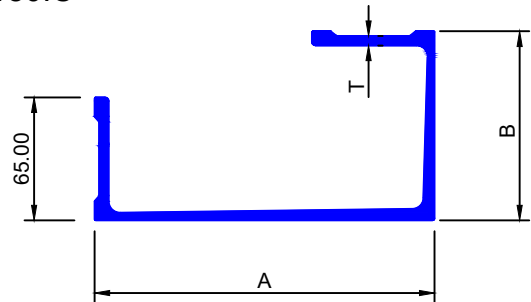

SEC.NO.	A	B	T	WT.Kg/mtr.
5494	180.00	100.00	5.00	5.603

230T/BEAM BOTTOM 100

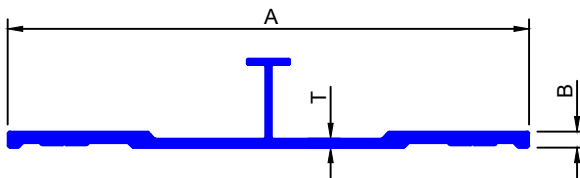

SEC.NO.	A	B	T	WT.Kg/mtr.
5495	230.00	7.00	4.00	3.491

210T/BEAM BOTTOM 80

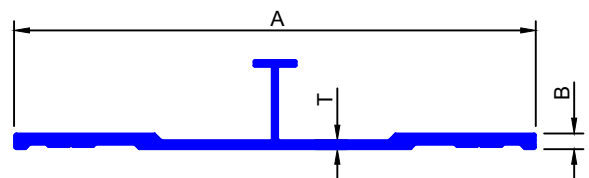

SEC.NO.	A	B	T	WT.Kg/mtr.
5496	210.00	7.00	4.00	3.275

TUBE WITH INSIDE SLOT

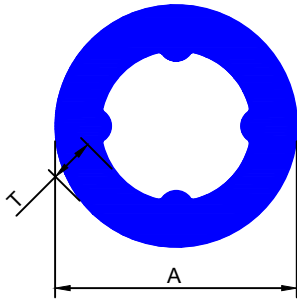

SEC.NO.	A	B	T	WT.Kg/mtr.
5497	16.00	-----	3.00	0.341

FIN PODIUM

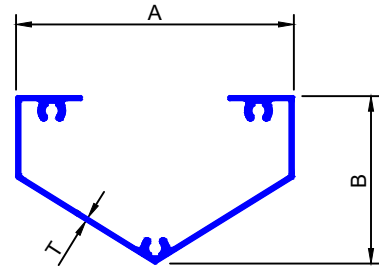

SEC.NO.	A	B	T	WT.Kg/mtr.
5498	85.00	51.29	1.30	0.866

KFCWW CENTER BAR

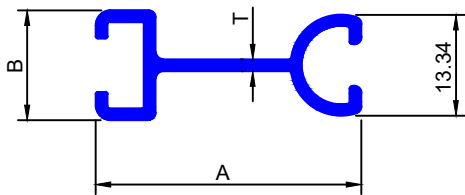

SEC.NO.	A	B	T	WT.Kg/mtr.
5499	35.18	14.54	1.57	0.318

KFCWW

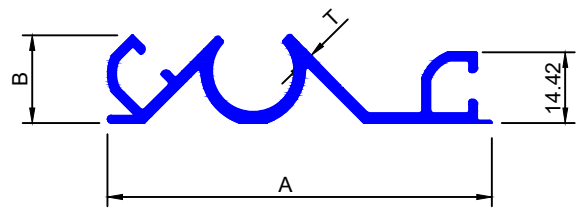

SEC.NO.	A	B	T	WT.Kg/mtr.
6600	78.23	17.88	2.06	0.855

FIBER SHEET

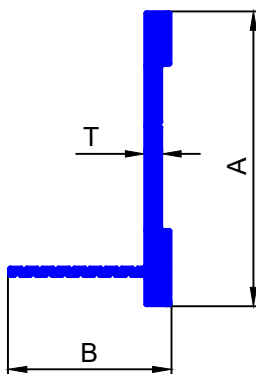

SEC.NO.	A	B	T	WT.Kg/mtr.
6601	65.00	36.00	4.00	1.029

DRIP MOLD

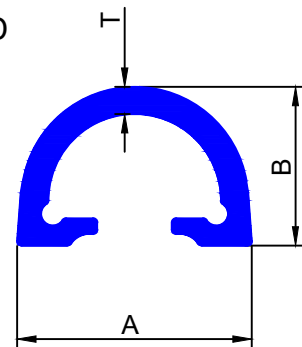

SEC.NO.	A	B	T	WT.Kg/mtr.
6602	25.89	17.50	3.00	0.426



100 mm END CAP

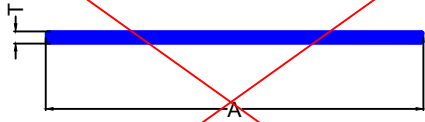

SEC.NO.	A	B	T	WT.Kg/mtr.
6603	100.00	-----	3.20	0.863

83 mm END CAP

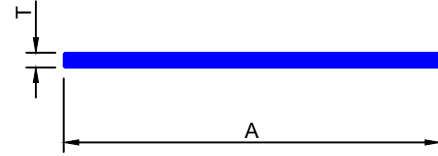

SEC.NO.	A	B	T	WT.Kg/mtr.
6604	83.00	-----	3.20	0.716

FIBER SHEET

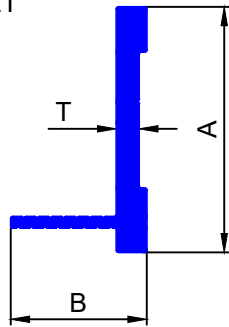

SEC.NO.	A	B	T	WT.Kg/mtr.
6605	65.00	36.00	6.00	1.425

300 DECK PANEL /300 L

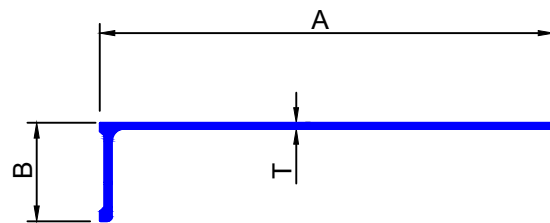

SEC.NO.	A	B	T	WT.Kg/mtr.
6606	300.00	65.00	4.00	4.177

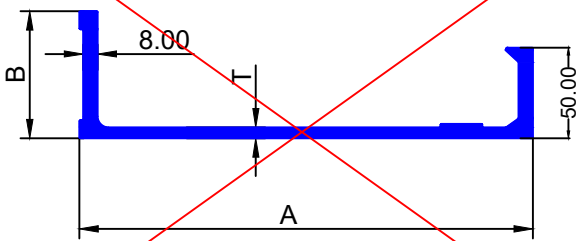

SEC.NO.	A	B	T	WT.Kg/mtr.
6607	250.00	70.00	6.00	6.738

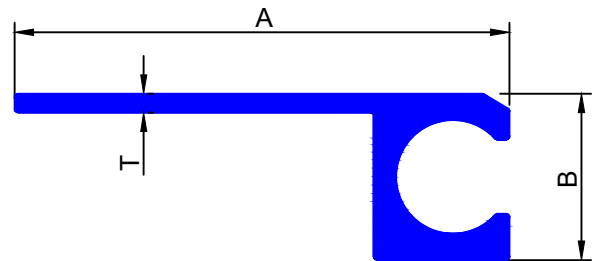

SEC.NO.	A	B	T	WT.Kg/mtr.
6608	65.50	22.00	2.50	0.886

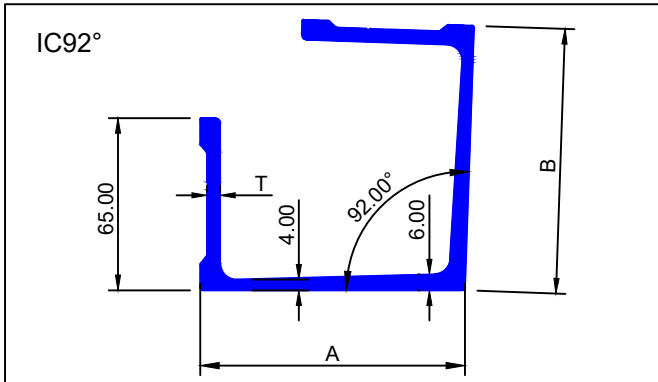

SEC.NO.	A	B	T	WT.Kg/mtr.
6609	100.00	100.00	5.00	4.559

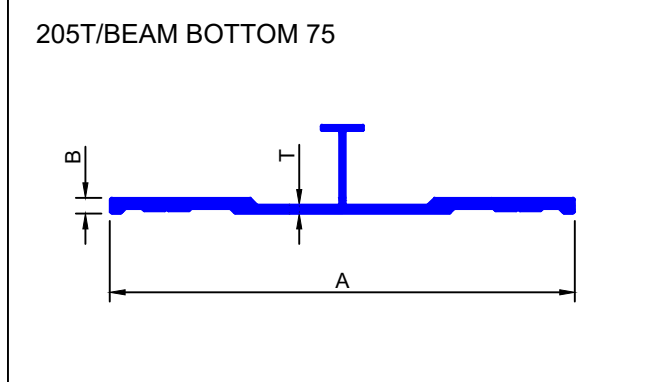

SEC.NO.	A	B	T	WT.Kg/mtr.
6610	205.00	7.00	4.00	3.221

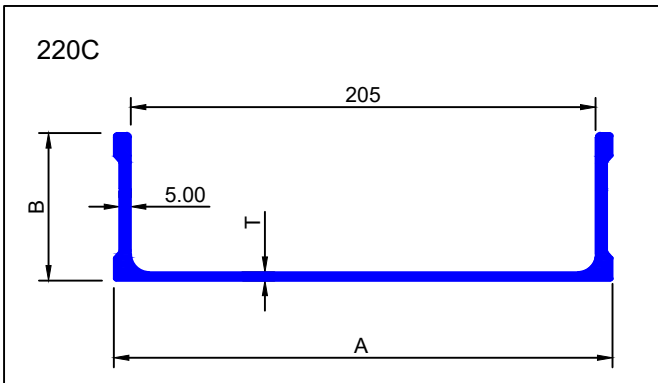

SEC.NO.	A	B	T	WT.Kg/mtr.
6611	220.00	65.00	3.70	4.178

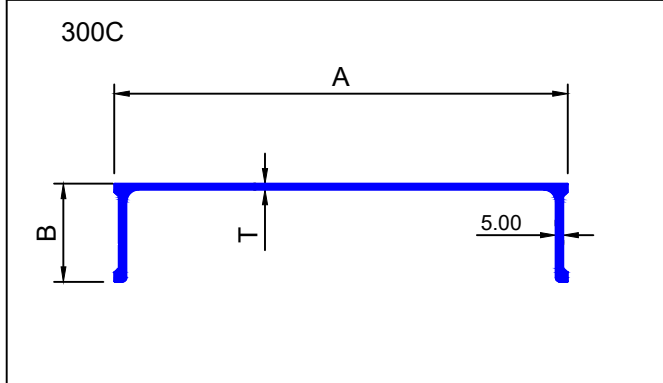

SEC.NO.	A	B	T	WT.Kg/mtr.
6612	299.50	65.00	4.00	5.125

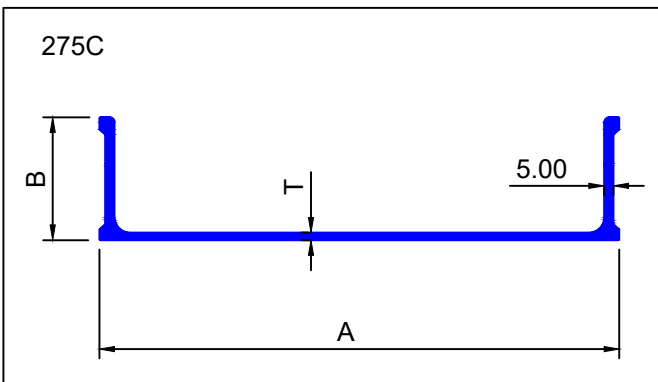

SEC.NO.	A	B	T	WT.Kg/mtr.
6613	274.50	65.00	4.00	4.855

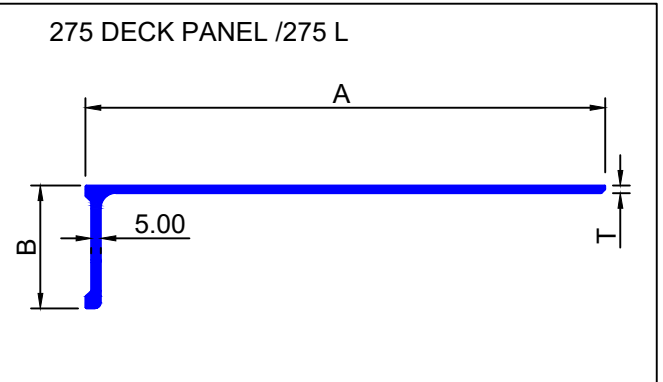

SEC.NO.	A	B	T	WT.Kg/mtr.
6614	274.50	65.00	4.00	3.907

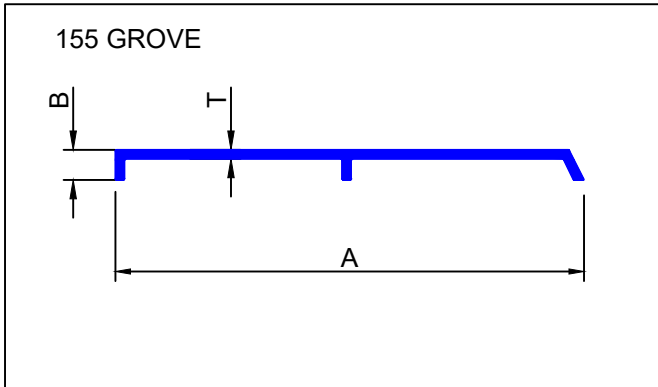

SEC.NO.	A	B	T	WT.Kg/mtr.
6615	155.00	10.00	3.00	1.397

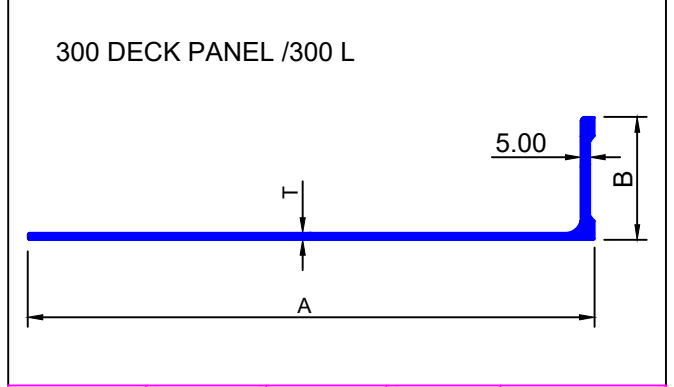

SEC.NO.	A	B	T	WT.Kg/mtr.
6616	300.00	65.00	3.70	3.987

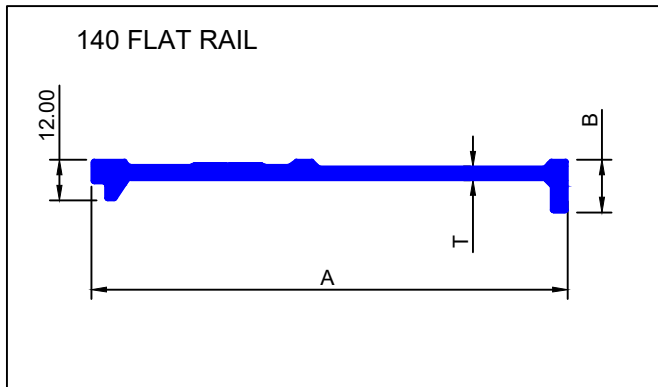

SEC.NO.	A	B	T	WT.Kg/mtr.
6618	140.00	15.50	4.00	1.954

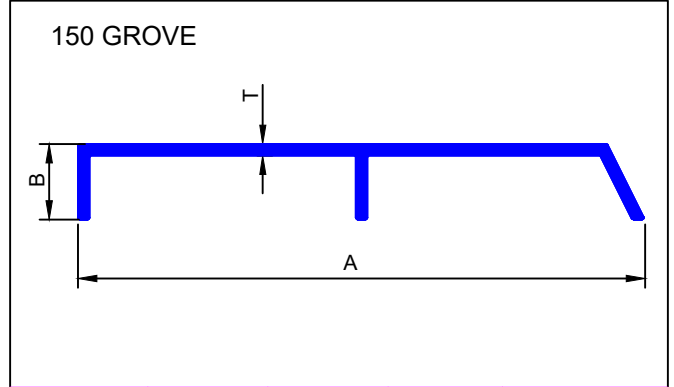

SEC.NO.	A	B	T	WT.Kg/mtr.
6619	150.00	20.00	3.00	1.568

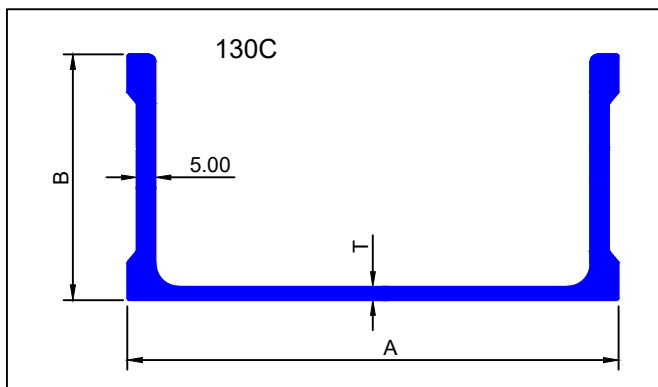

SEC.NO.	A	B	T	WT.Kg/mtr.
6620	130.00	65.00	3.50	3.187

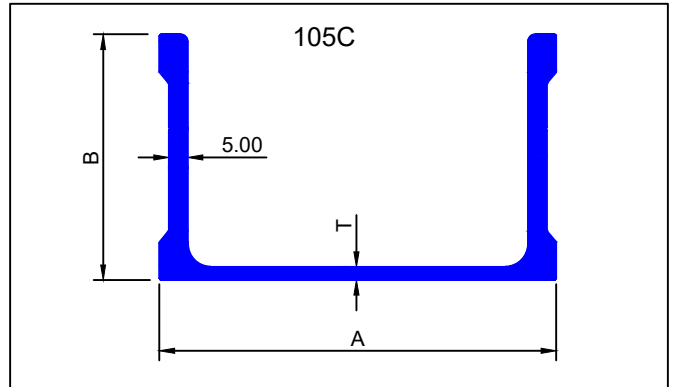

SEC.NO.	A	B	T	WT.Kg/mtr.
6621	105.00	65.00	3.50	2.951

C CHANNEL

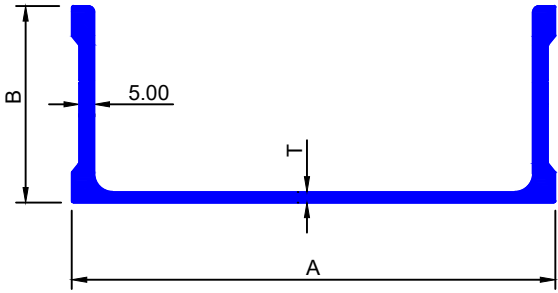

SEC.NO.	A	B	T	WT.Kg/mtr.
6622	160.00	65.00	3.50	3.471
6623	180.00	65.00	3.70	3.782
6624	190.00	65.00	3.70	3.881
6625	230.00	65.00	3.70	4.281
6626	100.00	65.00	3.50	2.904
6627	175.00	65.00	3.70	3.732
6628	200.00	65.00	3.70	3.981
6630	195.00	65.00	3.70	3.931
6631	250.00	65.00	3.70	4.481

175IC

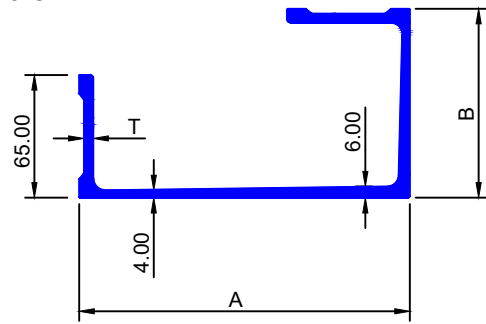

SEC.NO.	A	B	T	WT.Kg/mtr.
6629	175.00	100.00	5.00	5.571

140IC

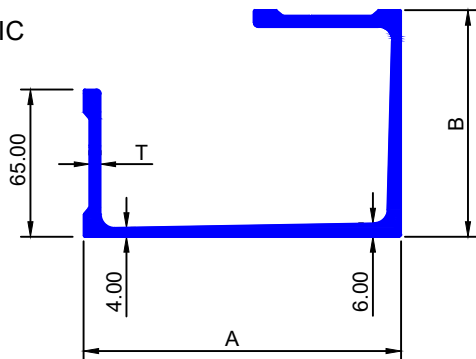

SEC.NO.	A	B	T	WT.Kg/mtr.
6632	140.00	100.00	5.00	5.099

255T/BEAM BOTTOM 125

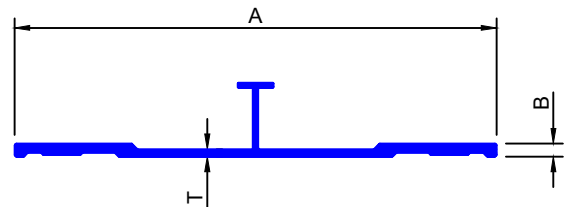

SEC.NO.	A	B	T	WT.Kg/mtr.
6633	255.00	7.00	4.00	3.763

150 EB/MB

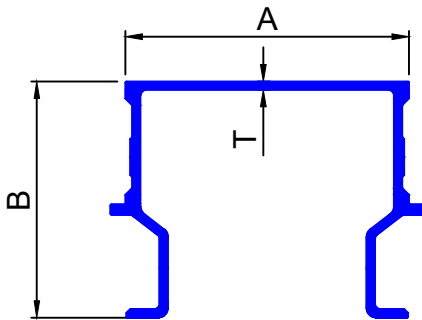

SEC.NO.	A	B	T	WT.Kg/mtr.
6634	150.00	125.00	4.50	6.022

DECK PROP

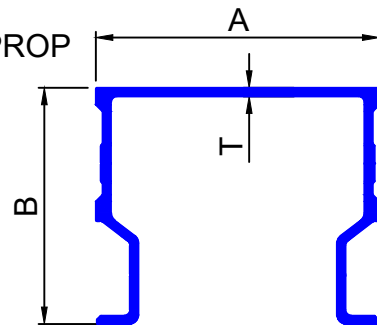

SEC.NO.	A	B	T	WT.Kg/mtr.
6635	150.00	125.00	4.50	5.784

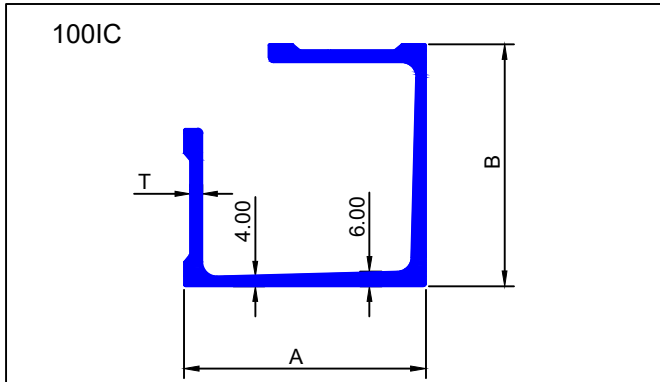

SEC.NO.	A	B	T	WT.Kg/mtr.
6636	100.00	100.00	5.00	4.557

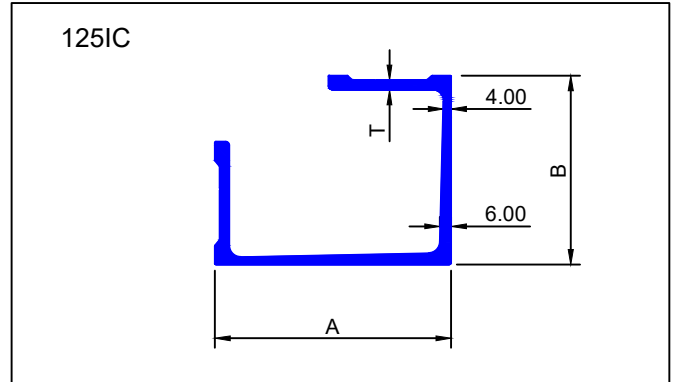

SEC.NO.	A	B	T	WT.Kg/mtr.
6637	125.00	100.00	5.00	4.895

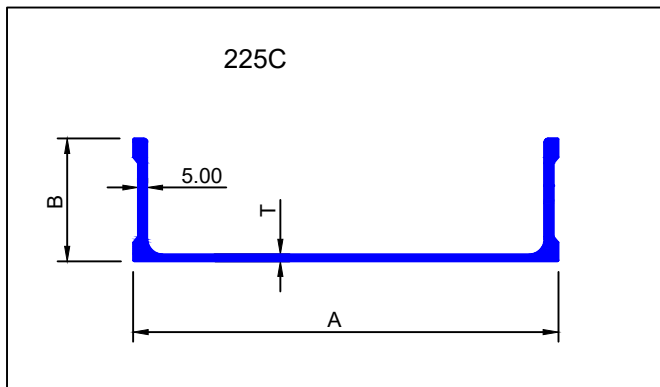

SEC.NO.	A	B	T	WT.Kg/mtr.
6638	225.00	65.00	3.70	4.230

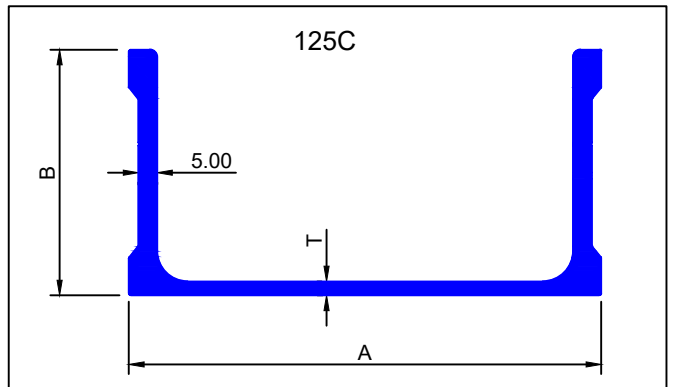

SEC.NO.	A	B	T	WT.Kg/mtr.
6639	125.00	65.00	3.70	3.231

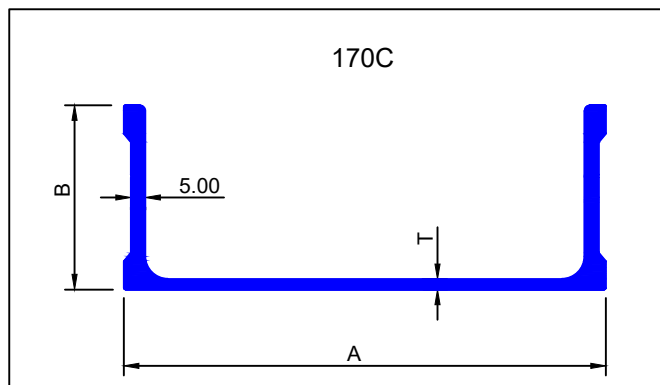

SEC.NO.	A	B	T	WT.Kg/mtr.
6640	170.00	65.00	3.70	3.680

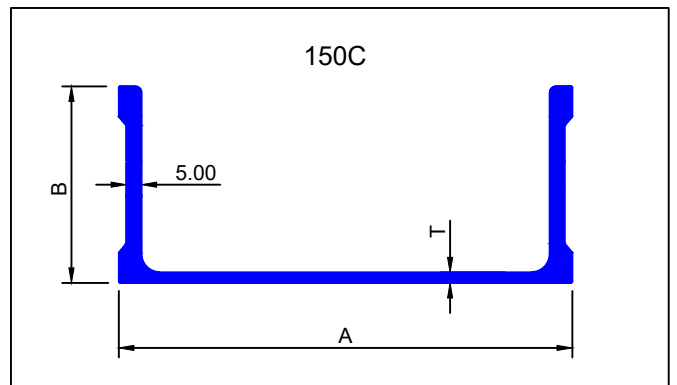

SEC.NO.	A	B	T	WT.Kg/mtr.
6641	150.00	65.00	3.50	3.375

DRIP MOLD

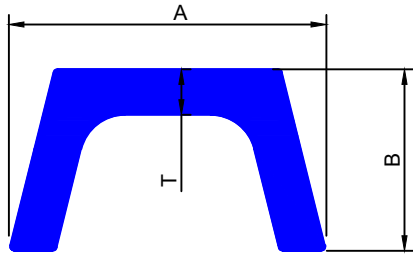

SEC.NO.	A	B	T	WT.Kg/mtr.
6642	21.00	12.00	3.00	0.283

200 DECK PANEL /200 L

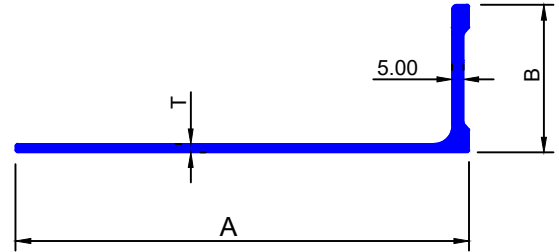

SEC.NO.	A	B	T	WT.Kg/mtr.
6643	200.00	65.00	3.70	2.987

250 DECK PANEL /250 L

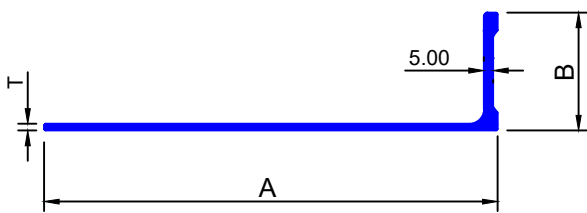

SEC.NO.	A	B	T	WT.Kg/mtr.
6644	250.00	65.00	3.70	3.487

TERRACE FLUTING

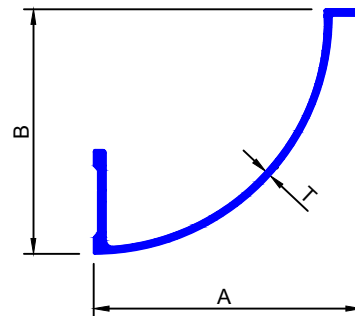

SEC.NO.	A	B	T	WT.Kg/mtr.
6645	168.39	154.00	4.00	3.763

J-75 PROFILE

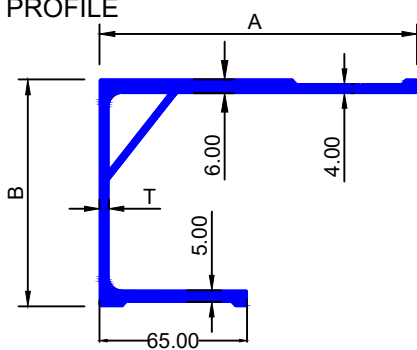

SEC.NO.	A	B	T	WT.Kg/mtr.
6646	140.00	100.00	4.00	4.301

J-80 PROFILE

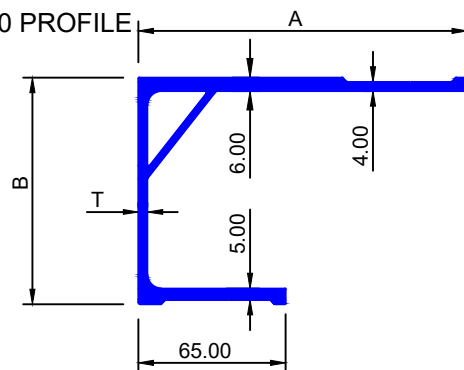

SEC.NO.	A	B	T	WT.Kg/mtr.
6647	145.00	100.00	4.00	4.382

100 mm GROOVE

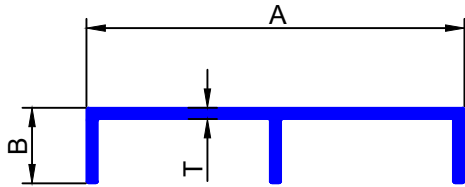

SEC.NO.	A	B	T	WT.Kg/mtr.
6648	100.00	20.00	3.00	1.222

BOX STIFFNER

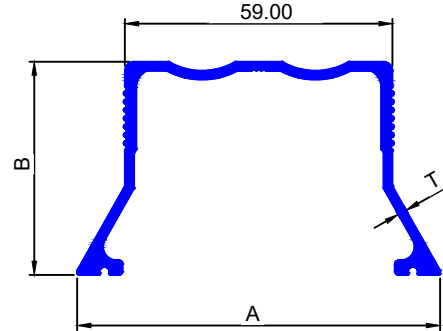

SEC.NO.	A	B	T	WT.Kg/mtr.
6649	80.00	47.00	2.00	1.038

FLAT ANGLE -100

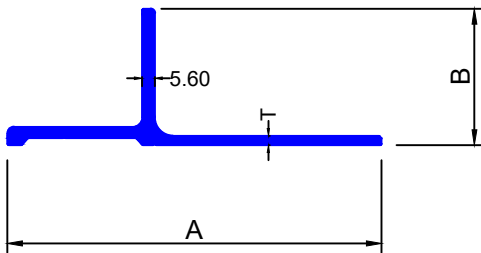

SEC.NO.	A	B	T	WT.Kg/mtr.
6650	165.00	60.00	4.00	2.899

61 mm FLAT RAIL

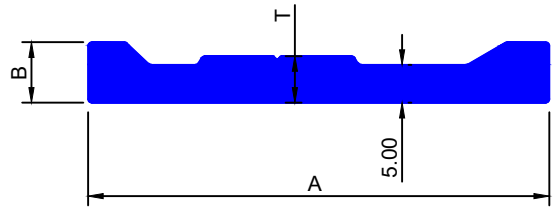

SEC.NO.	A	B	T	WT.Kg/mtr.
6651	61.00	8.00	6.15	1.006

65 mm FLAT RAIL

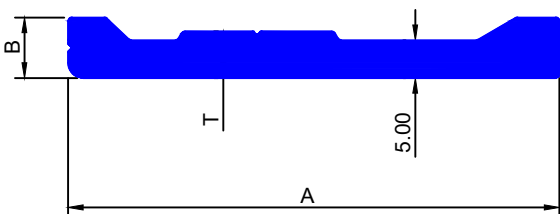

SEC.NO.	A	B	T	WT.Kg/mtr.
6652	65.00	8.00	6.15	1.058

150 mm IC

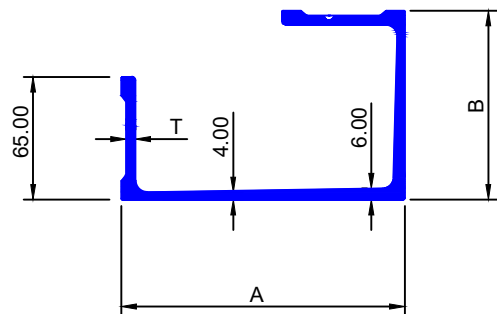

SEC.NO.	A	B	T	WT.Kg/mtr.
6653	150.00	100.00	5.00	5.234

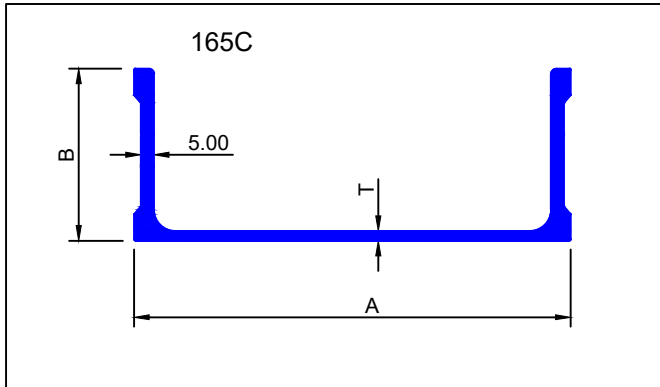

SEC.NO.	A	B	T	WT.Kg/mtr.
6654	165.00	65.00	3.70	3.632

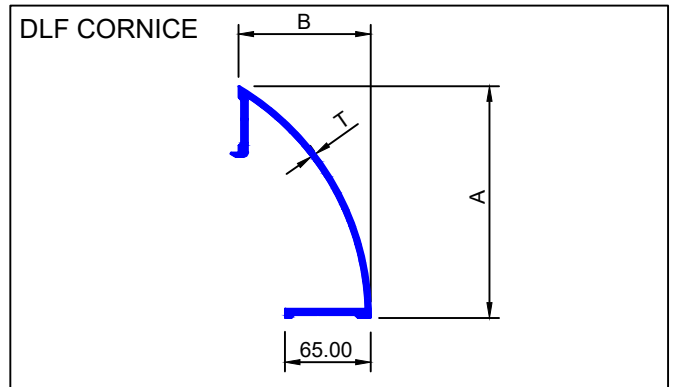

SEC.NO.	A	B	T	WT.Kg/mtr.
6655	175.00	100.00	4.00	3.879

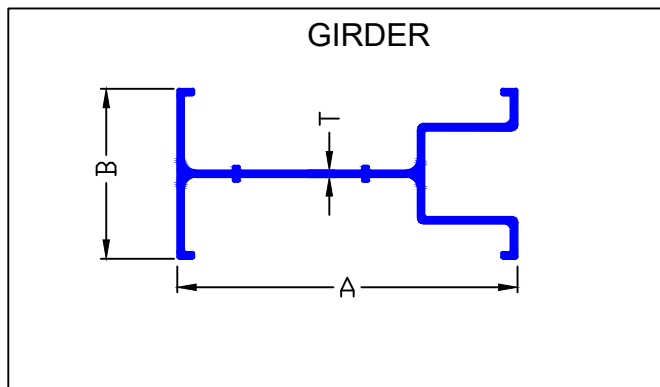

SEC.NO.	A	B	T	WT.Kg/mtr.
6656	150.00	75.00	3.00	2.970

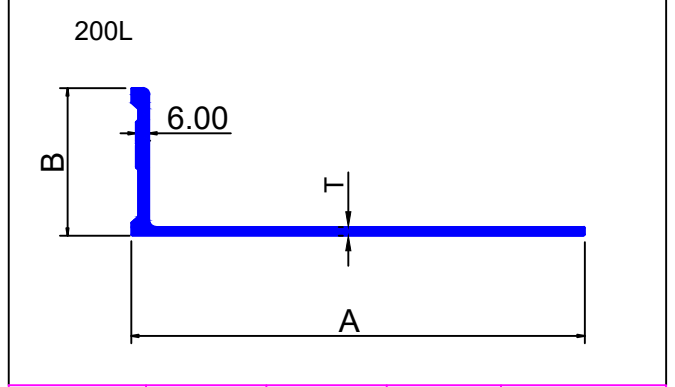

SEC.NO.	A	B	T	WT.Kg/mtr.
6657	200.00	65.00	3.80	3.023

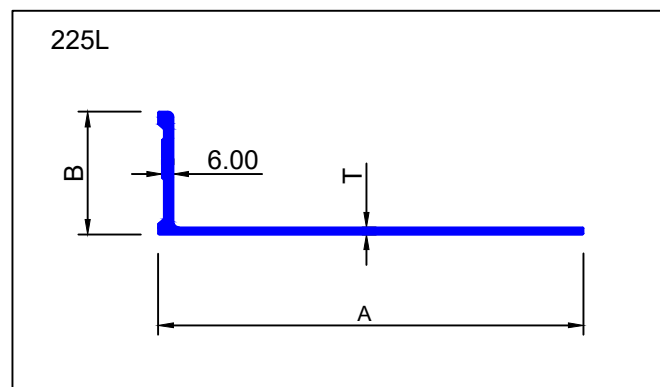

SEC.NO.	A	B	T	WT.Kg/mtr.
6658	225.00	65.00	3.80	3.280

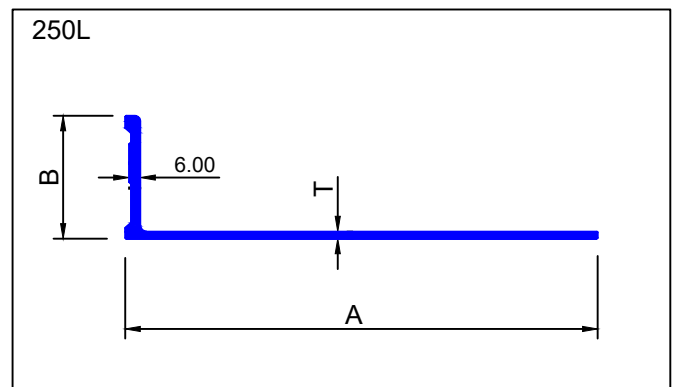

SEC.NO.	A	B	T	WT.Kg/mtr.
6659	250.00	65.00	3.80	3.536



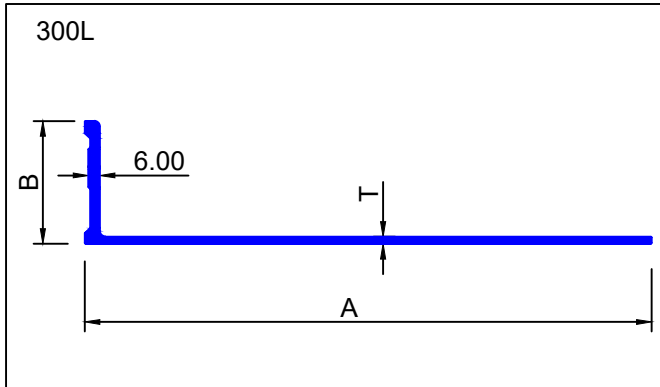

SEC.NO.	A	B	T	WT.Kg/mtr.
6660	300.00	65.00	3.80	4.049

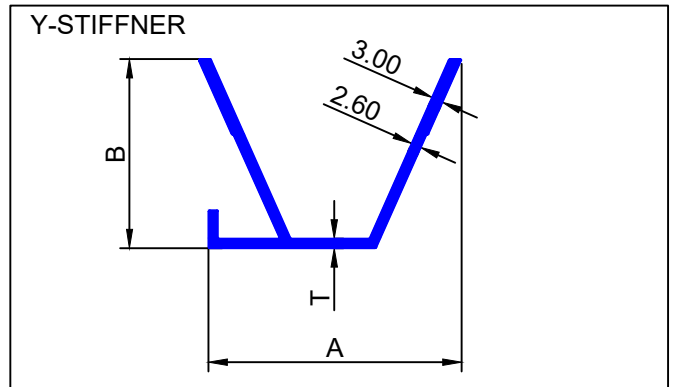

SEC.NO.	A	B	T	WT.Kg/mtr.
6661	67.00	50.00	2.50	1.130

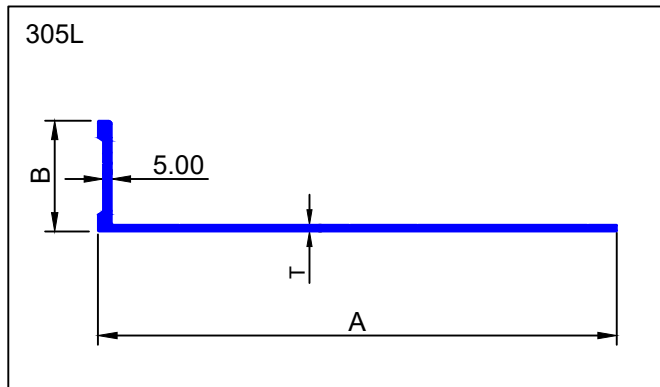

SEC.NO.	A	B	T	WT.Kg/mtr.
6662	305.00	65.00	3.80	4.096

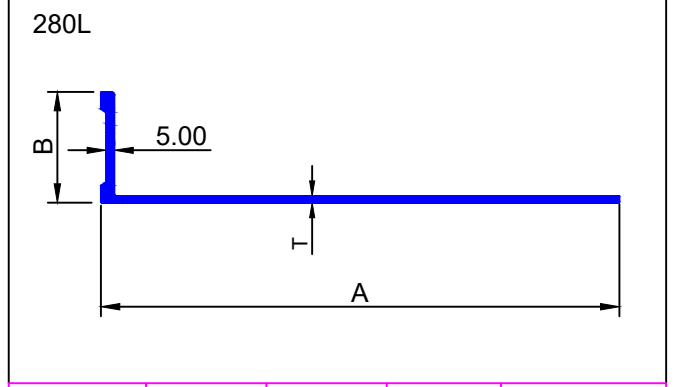

SEC.NO.	A	B	T	WT.Kg/mtr.
6663	280.00	65.00	3.80	3.840

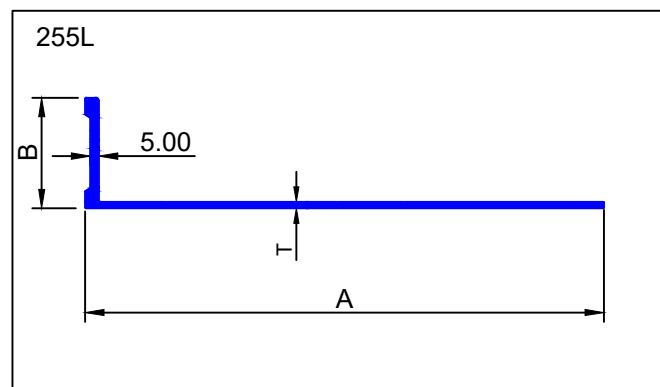

SEC.NO.	A	B	T	WT.Kg/mtr.
6664	255.00	65.00	3.80	3.584

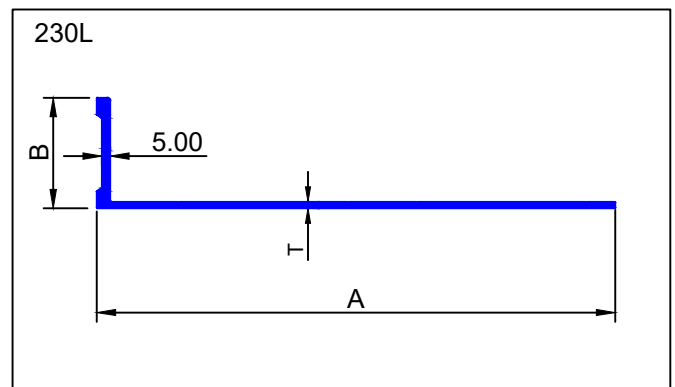

SEC.NO.	A	B	T	WT.Kg/mtr.
6665	230.00	65.00	3.80	3.327

205L

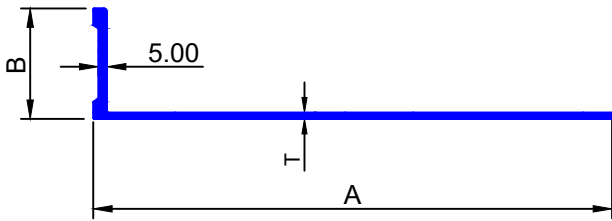

SEC.NO.	A	B	T	WT.Kg/mtr.
6666	205.00	65.00	3.80	3.071

FLAT RAIL

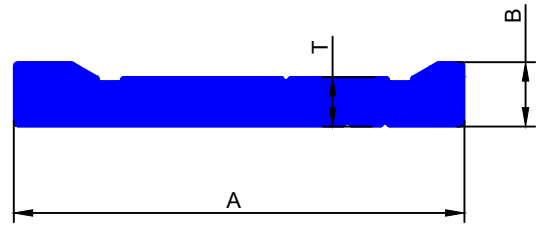

SEC.NO.	A	B	T	WT.Kg/mtr.
6667	59.60	8.50	6.50	1.115

FLAT RAIL

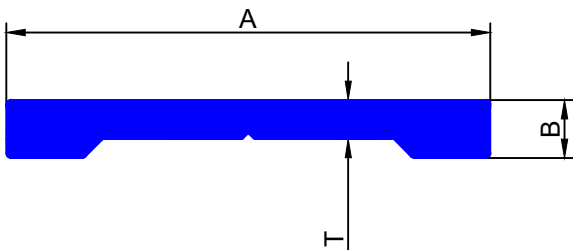

SEC.NO.	A	B	T	WT.Kg/mtr.
6668	50.00	6.00	4.00	0.635

TULIP GROOVE

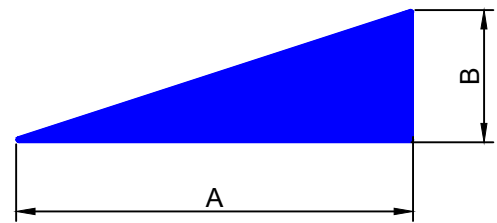

SEC.NO.	A	B	T	WT.Kg/mtr.
6669	150.00	50.00	-----	10.548

END RAIL

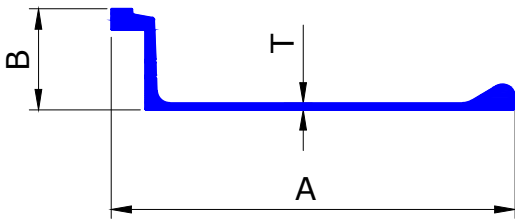

SEC.NO.	A	B	T	WT.Kg/mtr.
6670	152.70	39.10	2.50	1.770

SIDE RAIL

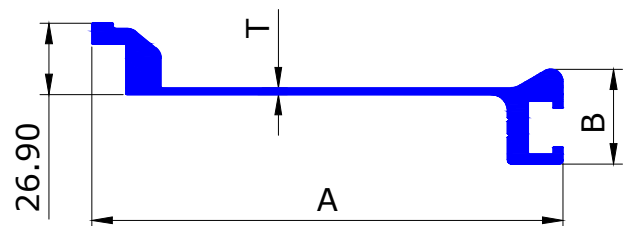

SEC.NO.	A	B	T	WT.Kg/mtr.
6671	178.10	35.80	2.50	3.124

100 mm END CAP

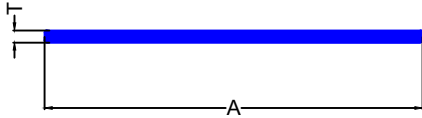

SEC.NO.	A	B	T	WT.Kg/mtr.
6672	100.00	-----	4.00	1.079

99.45 C

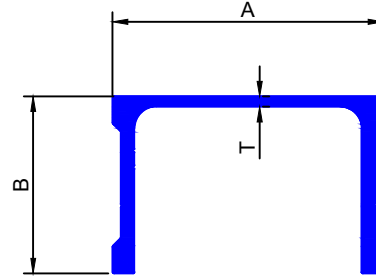

SEC.NO.	A	B	T	WT.Kg/mtr.
6673	99.45	65.00	3.80	3.052

124.45 C

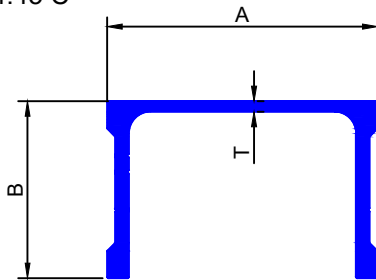

SEC.NO.	A	B	T	WT.Kg/mtr.
6674	124.45	65.00	3.80	3.309

149.45 C

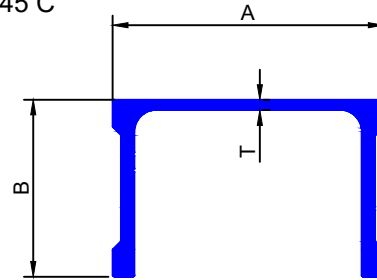

SEC.NO.	A	B	T	WT.Kg/mtr.
6675	149.45	65.00	3.80	3.565

49.50 EC/RK

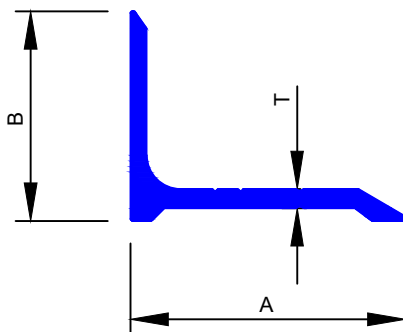

SEC.NO.	A	B	T	WT.Kg/mtr.
6676	65.00	49.50	4.50	1.273

131L

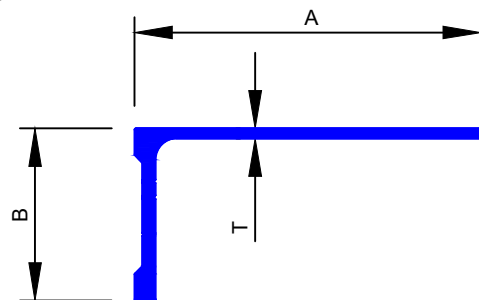

SEC.NO.	A	B	T	WT.Kg/mtr.
6677	131.00	65.00	3.80	2.358

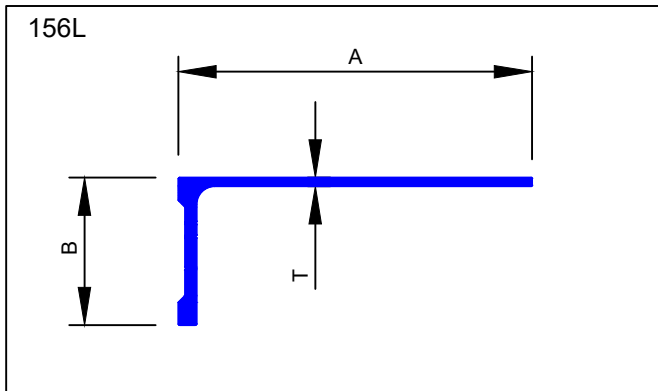

SEC.NO.	A	B	T	WT.Kg/mtr.
6678	156.00	65.00	3.80	2.615

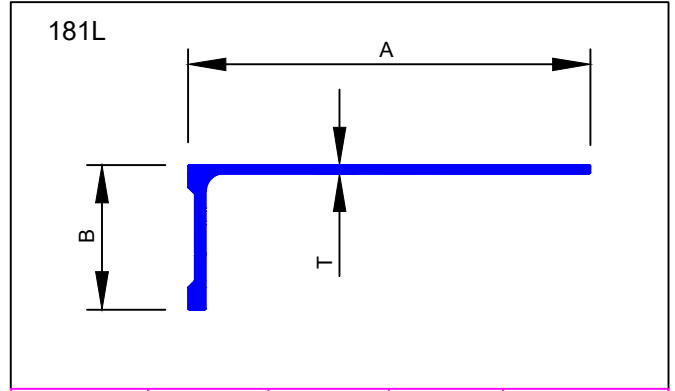

SEC.NO.	A	B	T	WT.Kg/mtr.
6679	181.00	65.00	3.80	2.871

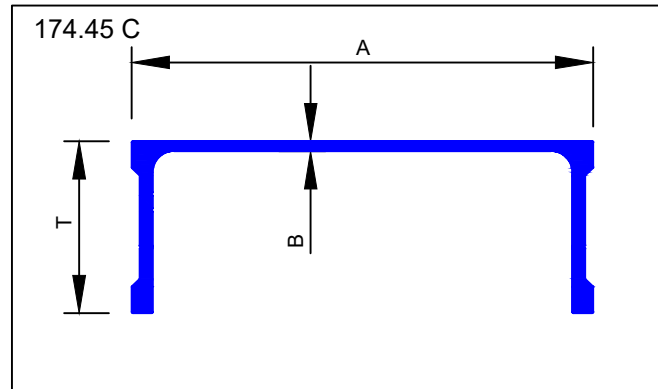

SEC.NO.	A	B	T	WT.Kg/mtr.
6680	174.45	65.00	3.80	3.822

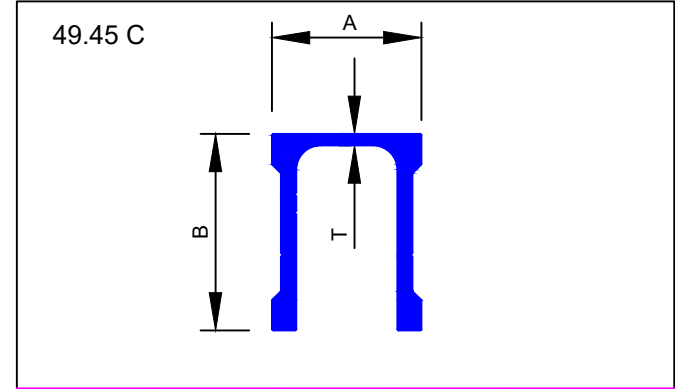

SEC.NO.	A	B	T	WT.Kg/mtr.
6681	49.45	65.00	3.80	2.540

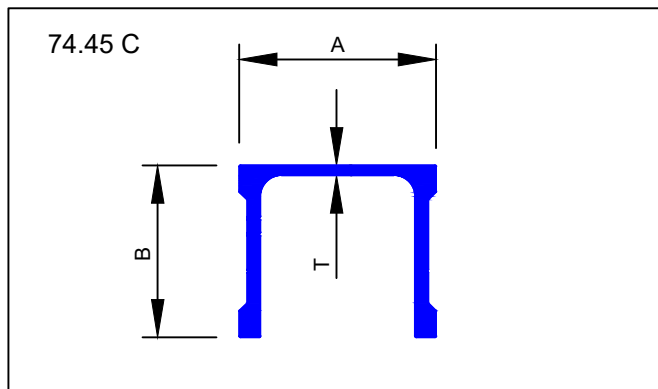

SEC.NO.	A	B	T	WT.Kg/mtr.
6682	74.45	65.00	3.80	2.796

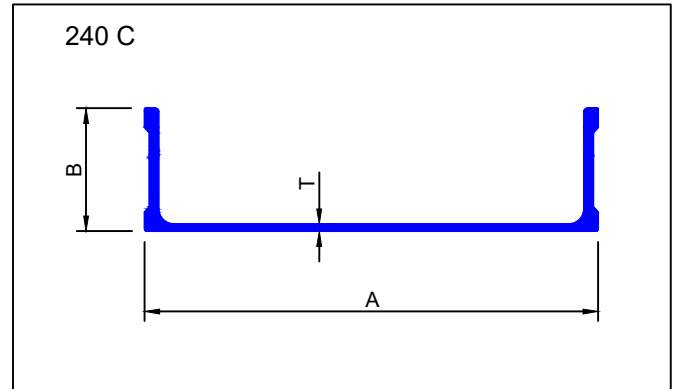

SEC.NO.	A	B	T	WT.Kg/mtr.
6683	240.00	65.00	3.70	4.380

TULIP GROOVE

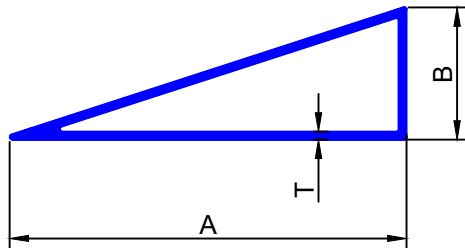

SEC.NO.	A	B	T	WT.Kg/mtr.
6684	150.00	50.00	3.00	2.777

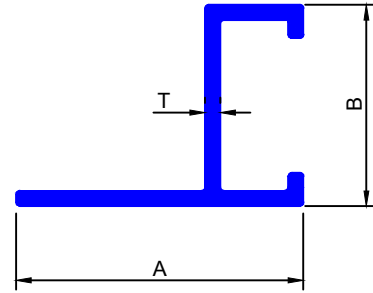

SEC.NO.	A	B	T	WT.Kg/mtr.
6685	38.00	26.60	2.00	0.422

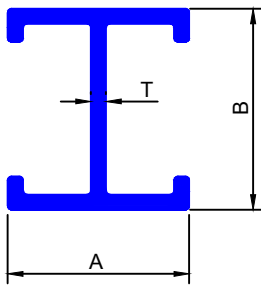

SEC.NO.	A	B	T	WT.Kg/mtr.
6686	24.00	26.60	2.00	0.432

100IC

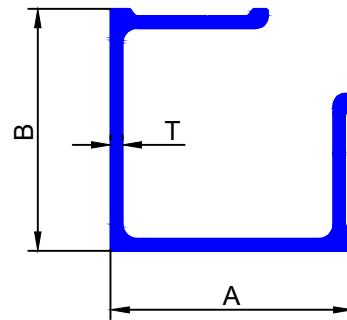

SEC.NO.	A	B	T	WT.Kg/mtr.
6687	100.00	100.00	5.00	4.460

200C

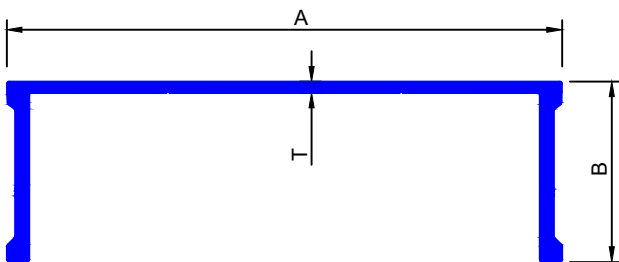

SEC.NO.	A	B	T	WT.Kg/mtr.
6688	200.00	65.00	4.00	3.999

250C

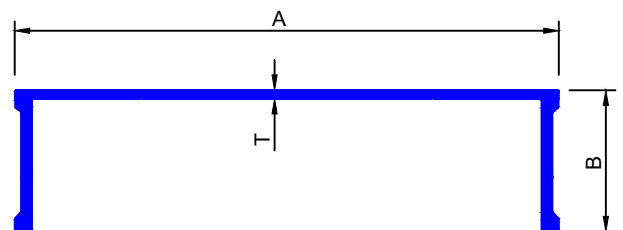

SEC.NO.	A	B	T	WT.Kg/mtr.
6689	250.00	65.00	4.00	4.539

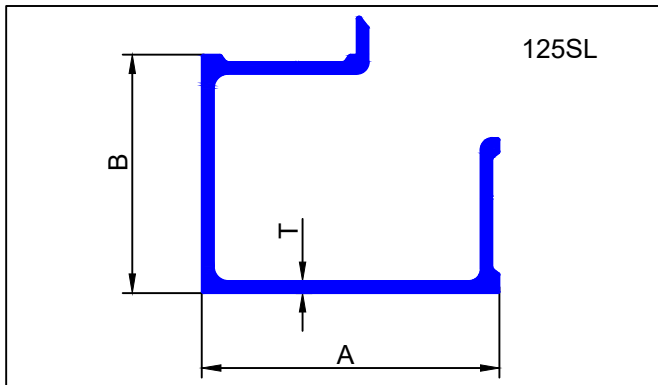

SEC.NO.	A	B	T	WT.Kg/mtr.
6690	125.00	100.00	5.00	5.076

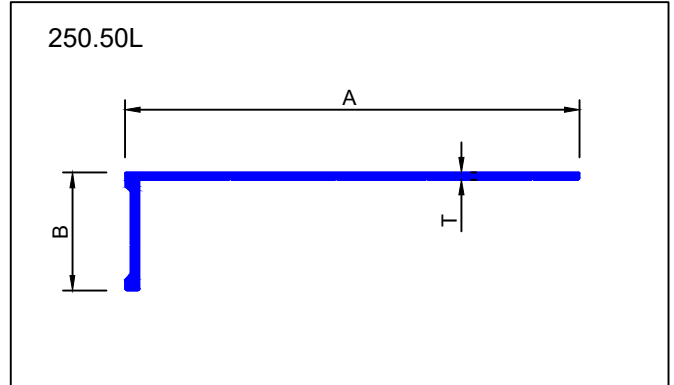

SEC.NO.	A	B	T	WT.Kg/mtr.
6691	250.50	65.00	4.00	3.619

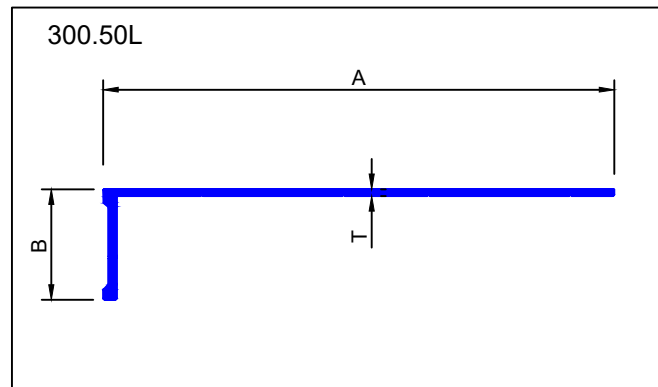

SEC.NO.	A	B	T	WT.Kg/mtr.
6692	300.50	65.00	4.00	4.159

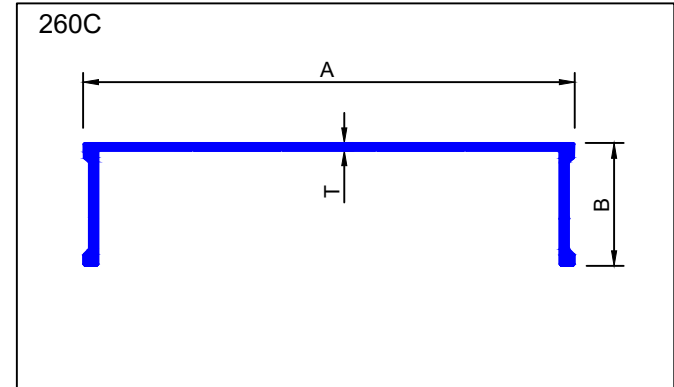

SEC.NO.	A	B	T	WT.Kg/mtr.
6693	260.00	65.00	4.00	4.646

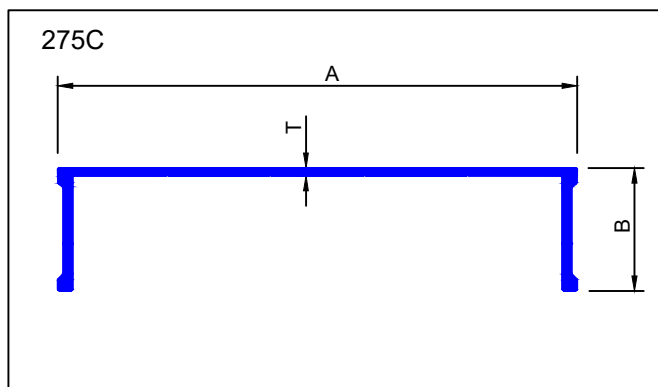

SEC.NO.	A	B	T	WT.Kg/mtr.
6694	275.00	65.00	4.00	4.808

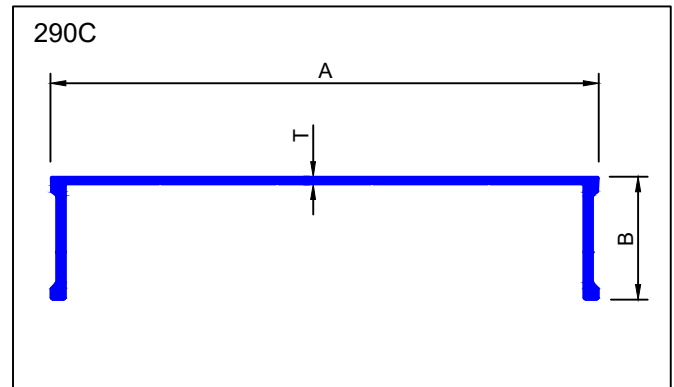

SEC.NO.	A	B	T	WT.Kg/mtr.
6695	290.00	65.00	4.00	4.970

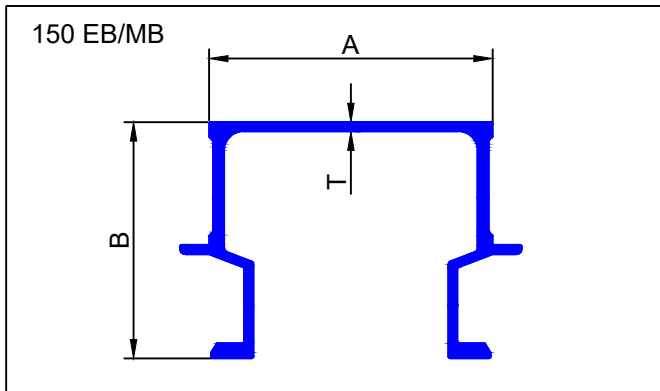

SEC.NO.	A	B	T	WT.Kg/mtr.
6696	150.00	125.00	5.00	7.272

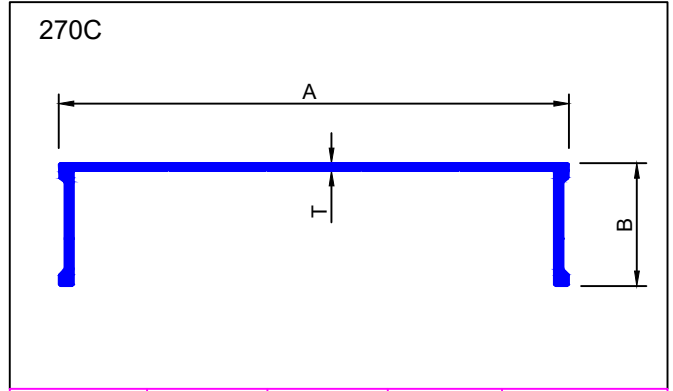

SEC.NO.	A	B	T	WT.Kg/mtr.
6697	270.00	65.00	4.00	4.754

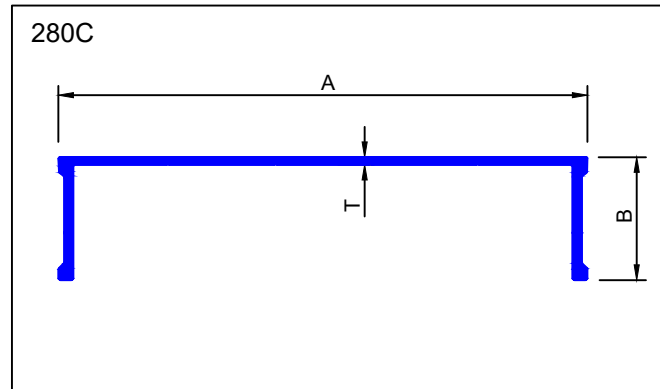

SEC.NO.	A	B	T	WT.Kg/mtr.
6698	280.00	65.00	4.00	4.862

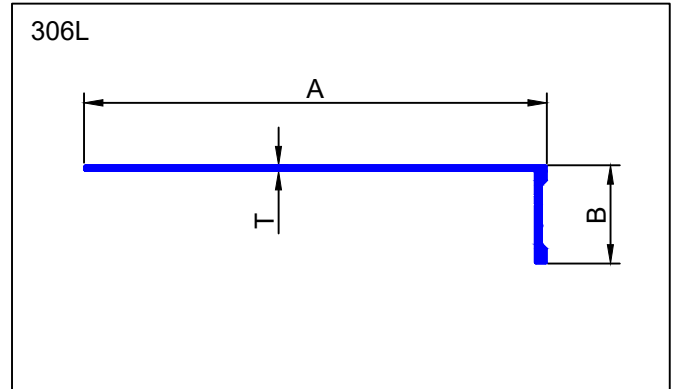

SEC.NO.	A	B	T	WT.Kg/mtr.
6699	306.00	65.00	3.80	4.116

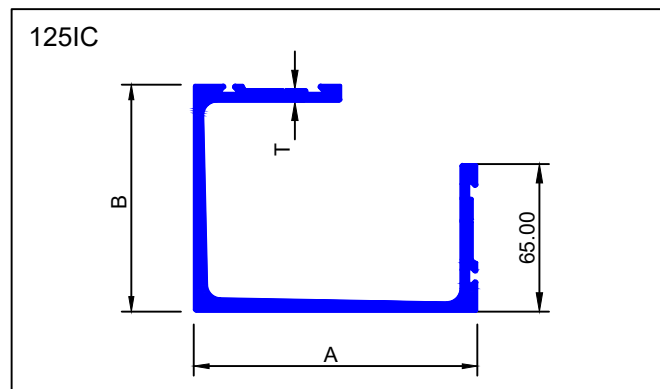

SEC.NO.	A	B	T	WT.Kg/mtr.
6700	125.00	100.00	5.50	4.862

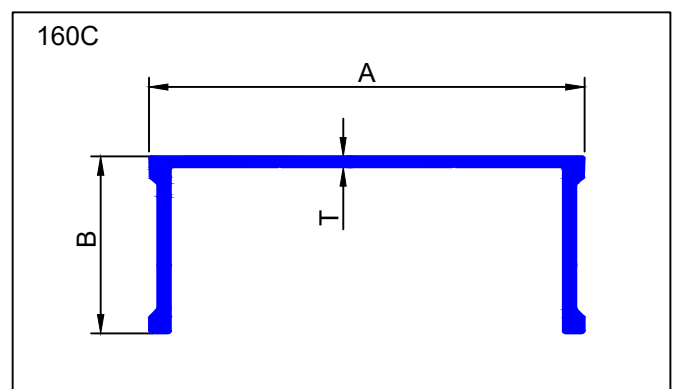

SEC.NO.	A	B	T	WT.Kg/mtr.
6701	160.00	65.00	4.00	3.567

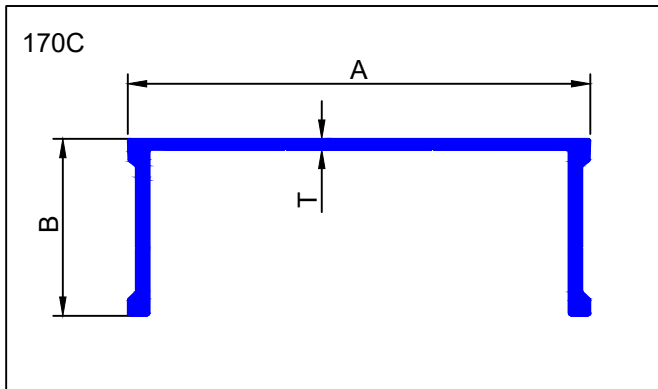

SEC.NO.	A	B	T	WT.Kg/mtr.
6702	170.00	65.00	4.00	3.675

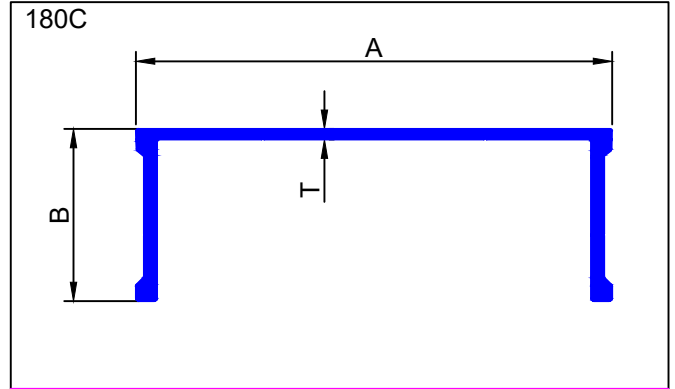

SEC.NO.	A	B	T	WT.Kg/mtr.
6703	180.00	65.00	4.00	3.783

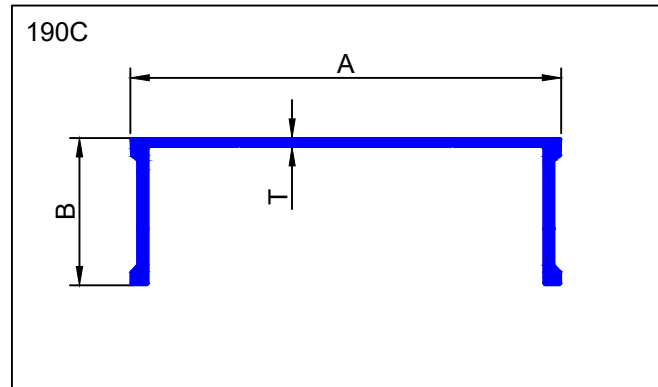

SEC.NO.	A	B	T	WT.Kg/mtr.
6704	190.00	65.00	4.00	3.891

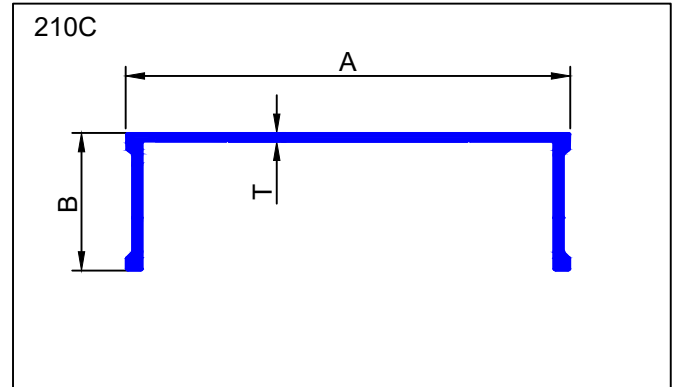

SEC.NO.	A	B	T	WT.Kg/mtr.
6705	210.00	65.00	4.00	4.107

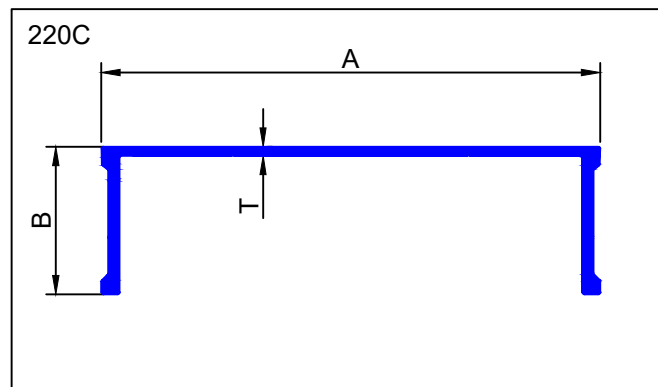

SEC.NO.	A	B	T	WT.Kg/mtr.
6706	220.00	65.00	4.00	4.215

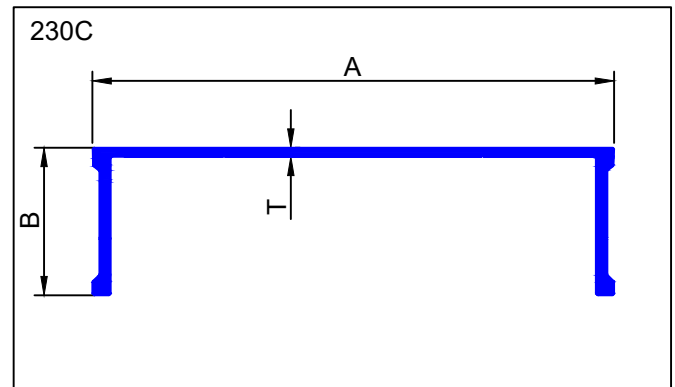

SEC.NO.	A	B	T	WT.Kg/mtr.
6707	230.00	65.00	4.00	4.323



240C

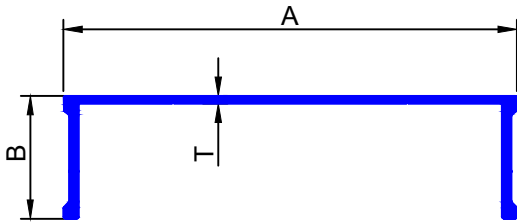

SEC.NO.	A	B	T	WT.Kg/mtr.
6708	240.00	65.00	4.00	4.431

100IC

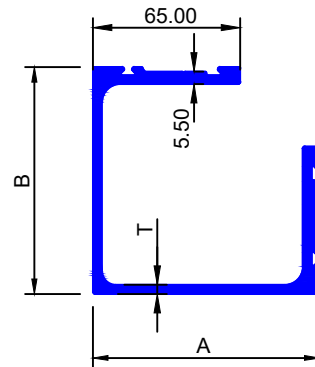

SEC.NO.	A	B	T	WT.Kg/mtr.
6709	100.00	100.00	4.00	4.182

150IC

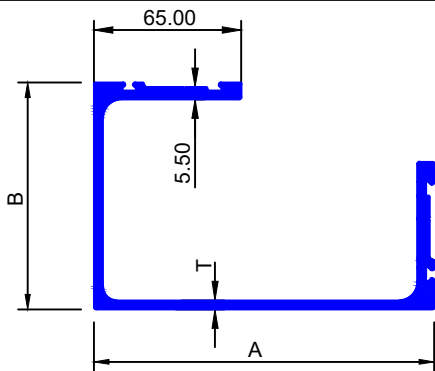

SEC.NO.	A	B	T	WT.Kg/mtr.
6710	150.00	100.00	4.00	4.722

J-50

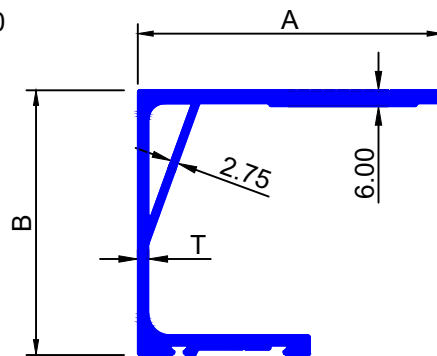

SEC.NO.	A	B	T	WT.Kg/mtr.
6711	115.00	100.00	4.00	4.157

100 MM EXPANSION JOINT/SWL-2

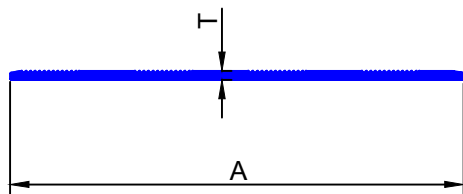

SEC.NO.	A	B	T	WT.Kg/mtr.
6712	200.00	-----	4.00	2.035

V-STIFFENER

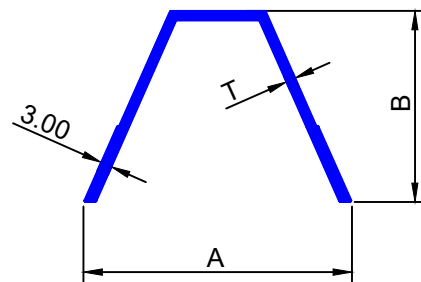

SEC.NO.	A	B	T	WT.Kg/mtr.
6713	71.00	50.50	2.53	0.952

100 MM EXPANSION JOINT/SWL-2

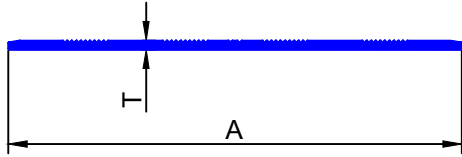

SEC.NO.	A	B	T	WT.Kg/mtr.
6714	200.00	-----	4.00	2.054

130 MM EXPANSION JOINT/SWL-2

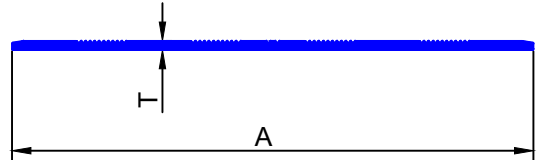

SEC.NO.	A	B	T	WT.Kg/mtr.
6715	230.00	-----	4.00	2.369

150 MM EXPANSION JOINT/SWL-2

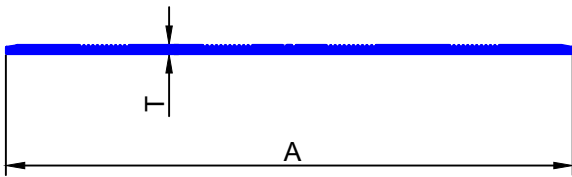

SEC.NO.	A	B	T	WT.Kg/mtr.
6716	250.00	-----	4.00	2.585

200 MM EXPANSION JOINT/SWL-2

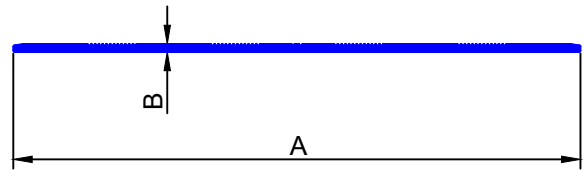

SEC.NO.	A	B	T	WT.Kg/mtr.
6717	300.00	-----	4.00	3.107

125 x 75 mm IC

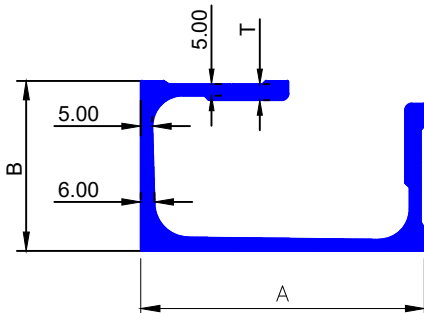

SEC.NO.	A	B	T	WT.Kg/mtr.
6718	125.00	75.00	7.00	5.347

J-90

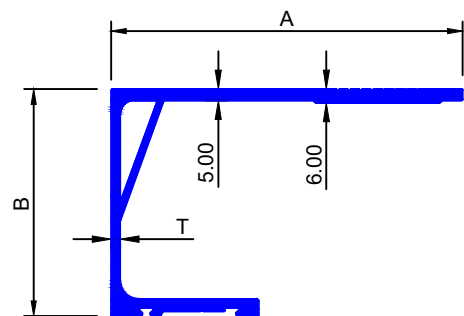

SEC.NO.	A	B	T	WT.Kg/mtr.
6719	155.00	100.00	4.00	4.697

175IC

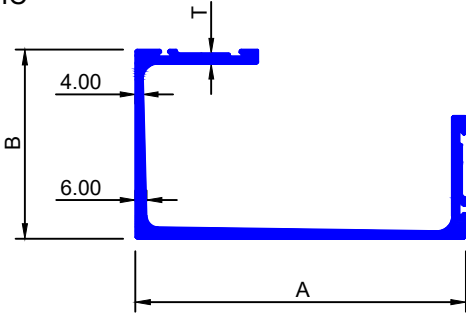

SEC.NO.	A	B	T	WT.Kg/mtr.
6720	175.00	100.00	5.50	5.660

300L

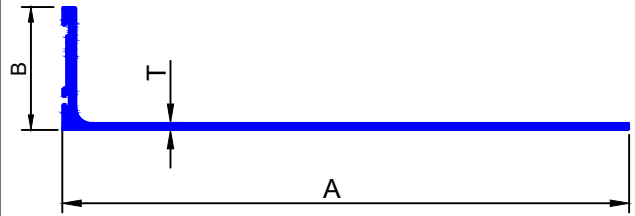

SEC.NO.	A	B	T	WT.Kg/mtr.
6721	300.00	65.00	3.70	4.025

200IC

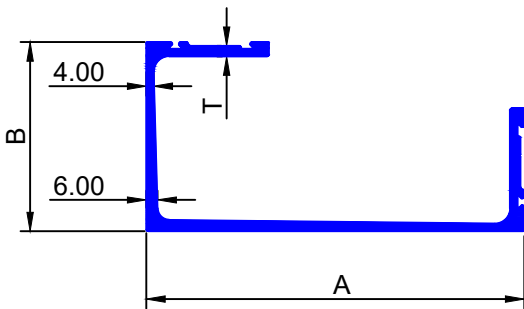

SEC.NO.	A	B	T	WT.Kg/mtr.
6722	200.00	100.00	5.50	5.999

305L

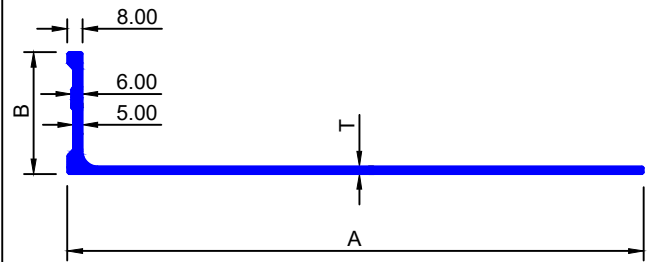

SEC.NO.	A	B	T	WT.Kg/mtr.
6723	305.00	64.50	4.00	4.295

150C

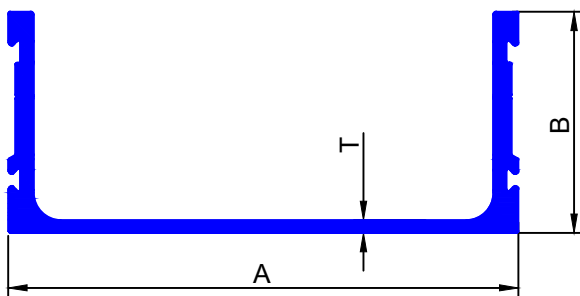

SEC.NO.	A	B	T	WT.Kg/mtr.
6724	150.00	65.00	3.70	3.555

120C

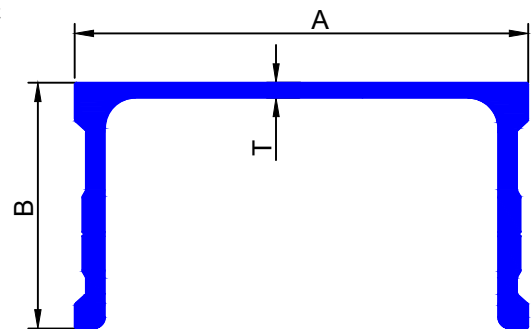

SEC.NO.	A	B	T	WT.Kg/mtr.
6725	120.00	65.00	4.00	3.365

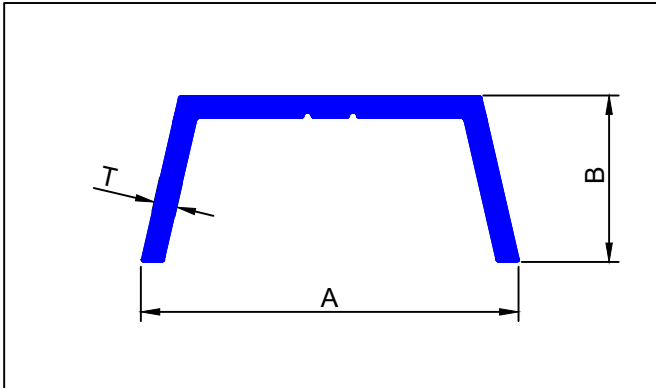

SEC.NO.	A	B	T	WT.Kg/mtr.
6726	50.00	22.00	3.00	0.641

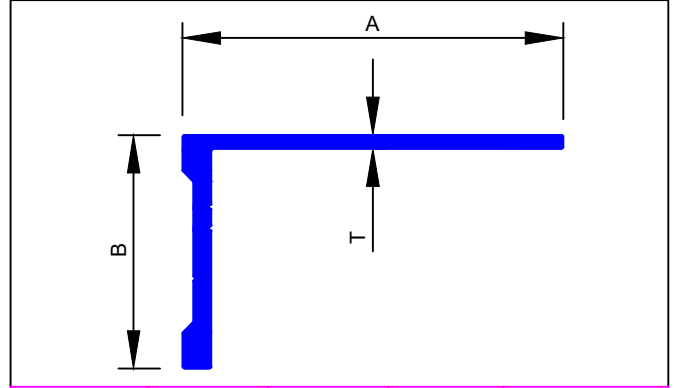

SEC.NO.	A	B	T	WT.Kg/mtr.
6727	106.00	65.00	3.80	2.064

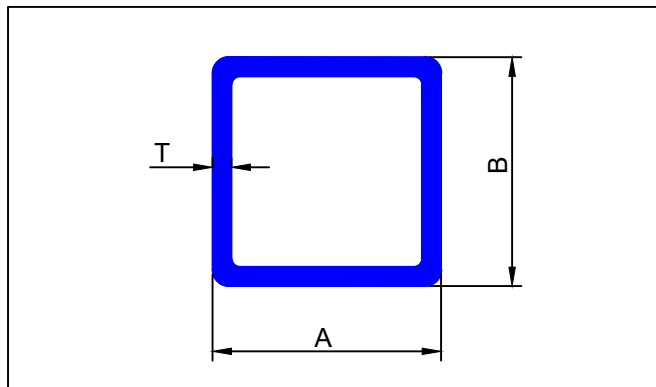

SEC.NO.	A	B	T	WT.Kg/mtr.
6728	42.00	42.00	3.50	1.439

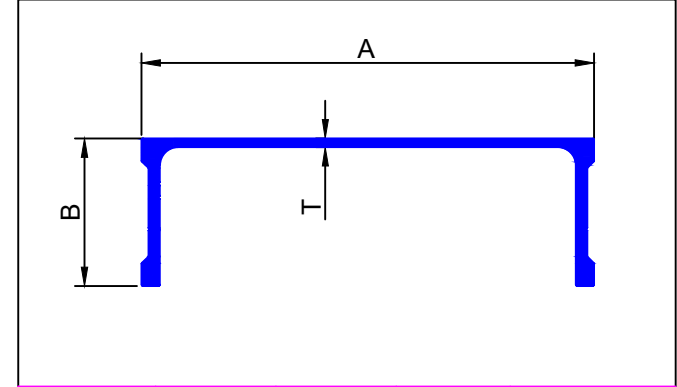

SEC.NO.	A	B	T	WT.Kg/mtr.
6729	199.50	65.00	3.80	4.077

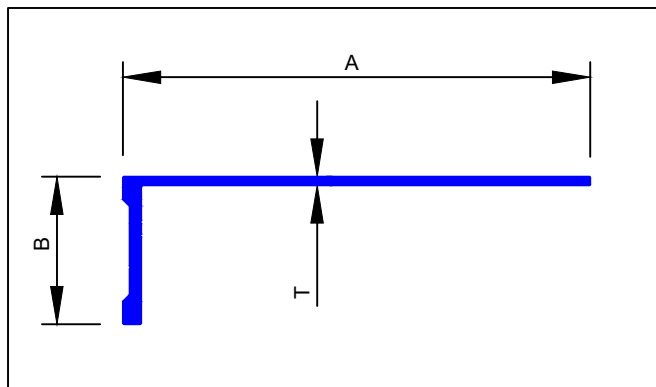

SEC.NO.	A	B	T	WT.Kg/mtr.
6730	206.00	65.00	3.80	3.090

## FLUTED TUBE

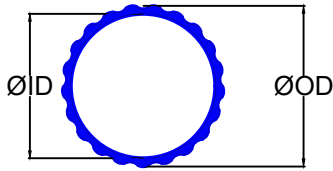

SEC.NO.	Ø OD	Ø ID	WT.Kg/mtr.
2501	25.00	20.20	0.390
2502	50.00	46.00	0.715

## ROUND TUBE

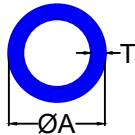

SEC.NO.	ØA	T	WT.Kg/mtr.
6040	9.52	1.77	0.116
6046	12.00	2.00	0.169
2600	16.00	2.50	0.286
2601	21.00	2.00	0.322
2602	22.00	3.00	0.483
6039	23.90	3.60	0.619
2603	25.00	2.00	0.390
2604	25.00	3.00	0.559
2605	25.00	4.00	0.712
2606	25.40	3.00	0.570
6001	25.50	8.75	1.243
6035	26.70	2.50	0.513
6043	26.85	3.55	0.701
2608	27.00	3.20	0.646
6036	27.00	3.70	0.731
6027	28.00	2.50	0.540
6029	29.60	4.95	1.034
2680	30.00	3.00	0.687
6024	30.60	3.80	0.618
2609	31.80	4.50	1.042
2611	32.00	2.00	0.508
2612	32.00	3.00	0.737
2613	32.00	3.50	0.846
6007	32.00	7.00	1.484
6019	32.00	10.50	1.914
6042	34.40	4.00	1.031
6037	35.00	5.00	1.272
2618	35.30	4.50	1.175
6038	35.40	4.75	1.234
2686	35.70	4.75	1.246
6020	35.70	4.95	1.291
6044	36.00	4.25	1.144
6004	36.00	12.50	2.491
6000	36.10	5.05	1.330
6045	36.40	5.15	1.365
2678	36.40	5.20	1.376

## ROUND TUBE

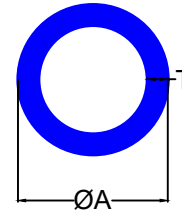

SEC.NO.	ØA	T	WT.Kg/mtr.
2679	36.40	5.00	1.331
6009	36.90	5.25	1.409
2619	37.00	7.00	1.781
6011	37.10	5.30	1.429
2620	38.00	3.00	0.890
2622	38.00	6.50	1.736
2625	40.00	3.00	0.941
6015	40.00	6.50	1.847
2673	41.60	4.50	1.416
6034	41.80	4.75	1.492
2685	41.90	4.75	1.496
6010	42.10	4.80	1.518
6008	42.20	4.60	1.459
6030	42.50	4.95	1.576
6005	44.05	5.60	1.826
2627	45.00	5.00	1.696
2674	48.10	4.60	1.697
2684	48.20	4.75	1.750
2681	48.40	4.75	1.758
2628	48.50	4.60	1.712
2698	50.00	2.50	1.007
2629	50.00	3.00	1.195
6023	50.00	3.50	1.380
2630	50.00	4.00	1.560
2631	50.00	5.00	1.908
2632	50.00	6.00	2.239
2633	50.00	8.00	2.850
6041	50.00	10.00	3.392
2634	50.00	11.00	3.638
2677	50.00	12.50	3.976
6014	50.00	18.00	4.885
6047	51.60	6.30	2.420
2635	52.00	2.50	1.049
6003	52.00	7.00	2.671
6021	52.00	16.00	4.885
2638	54.00	10.00	3.732
2692	55.00	14.00	4.868
2639	60.00	3.00	1.450
2640	60.00	5.00	2.332
6016	60.33	3.91	1.871
2641	60.80	6.40	2.953
2683	62.00	5.30	2.549
2642	63.00	3.00	1.526
2643	63.00	6.50	3.115
2695	65.00	2.00	1.068

## ROUND TUBE

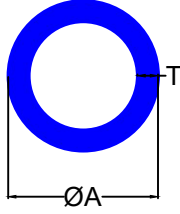

SEC.NO.	ØA	T	WT.Kg/mtr.
6031	65.00	13.50	5.897
2644	70.00	3.00	1.704
2645	70.00	4.50	2.500
6013	70.00	5.00	2.756
2646	70.00	6.00	3.257
2647	70.00	8.00	4.207
6012	70.00	10.00	5.089
6017	70.00	25.00	9.542
6022	73.03	5.16	2.969
2693	75.00	3.00	1.832
2699	75.00	4.00	2.408
2696	75.00	5.00	2.968
2697	75.00	7.50	4.294
2694	75.00	12.50	6.626
6006	75.00	17.50	8.535
2649	76.00	3.50	2.152
2650	76.00	6.00	3.562
2675	76.00	6.35	3.751
2652	76.00	6.50	3.831
6032	78.00	2.50	1.601
2653	80.00	4.00	2.578
2654	86.00	2.25	1.598
2655	89.00	6.00	4.224
2656	89.00	6.35	4.451
2676	89.00	8.00	5.496
2657	89.00	10.00	6.701
6002	90.00	32.00	15.743
6025	100.00	2.50	2.067
2671	100.00	3.00	2.468
6018	101.00	3.00	2.493
2682	105.00	2.50	2.173
2658	111.00	12.00	10.077
2659	112.00	17.00	13.699
2660	114.30	8.56	7.677
2661	115.00	3.50	3.310
6028	126.00	3.60	3.737
2662	132.00	11.00	11.290
2663	148.00	12.00	13.843
2664	150.00	4.00	4.953
6033	156.40	3.60	4.665
2666	160.00	3.50	4.646
2668	160.00	7.00	9.084

## ROUND TUBE

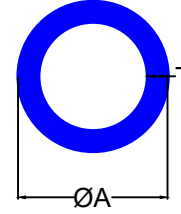

SEC.NO.	ØA	T	WT.Kg/mtr.
2669	163.00	6.50	8.629
6026	166.00	3.00	4.147
2670	180.00	15.00	20.994

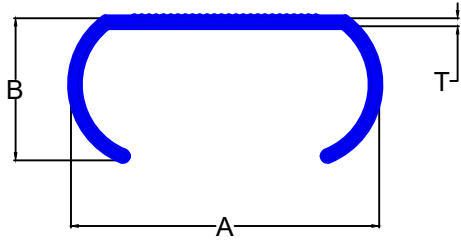

SEC.NO.	A	B	T	WT.Kg/mtr.
3401	68.00	31.30	1.80	0.618

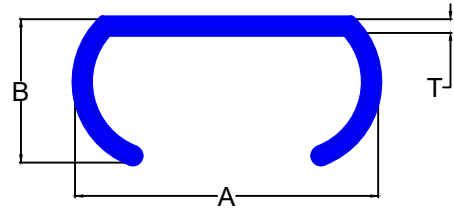

SEC.NO.	A	B	T	WT.Kg/mtr.
3404	66.50	31.60	2.00	0.691
3405	66.50	31.60	2.70	0.920
3406	66.50	31.60	3.00	1.015

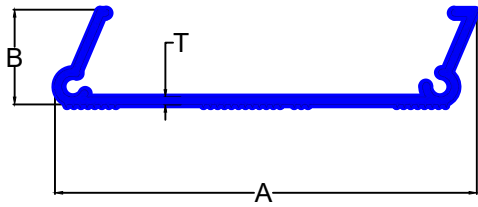

SEC.NO.	A	B	T	WT.Kg/mtr.
3408	93.00	21.00	1.60	0.622

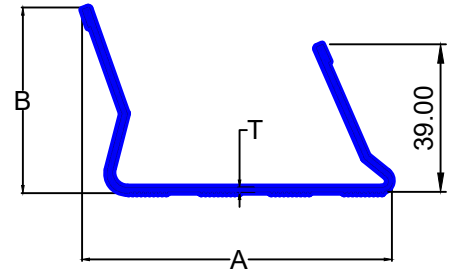

SEC.NO.	A	B	T	WT.Kg/mtr.
3409	82.00	49.00	1.15	0.611